



NABARD Uttar Pradesh Regional Office
11, Vipin Khand, Gomti Nagar, Lucknow, Uttar Pradesh-226010
Email: dpsp.lucknow@nabard.org

National Bank for Agriculture and Rural Development (NABARD) invites **E- Tender** for undertaking **Renovation of Visiting Officers Flat at La Place, Hazratganj, Uttar Pradesh Regional Office, NABARD, Lucknow**. Firms/Vendors may log on to the website of NABARD i.e. www.nabard.org or to the Central Public Procurement Portal i.e. <https://eprocure.gov.in> to download the Tender Document for submitting the same duly filled by **15 March 2024 by 15:00hrs**.

Date of issue of tender document	23.02.2024 at 09.00 hrs
Date and time of pre bid meeting	08.03.2024 at 15:00 hrs
Due date and time for submission of tender documents	15.03.2024 at 15.00 hrs
Date and time of opening Technical Bids	16.03.2024 at 15.30 hrs
Date and time of opening Financial Bids	Will be informed separately
Retention Money Deposit (RMD)	RMD @5% of total work order value shall have to be submitted by the vendor and will be deducted from first payment made by NABARD, till the Defect Liability Period of 01 year from date of the completion of the work.
Duration for work completion	45 days reckoned from the date of issue of Work Order

(Sign and seal of tenderer)

CONTENTS

Sr. No	Particulars	
PART I (Technical Bid)		
1	Notice Inviting Tender (Bilingual)	1-4
2	Prequalification criteria-Annexure I	5-6
3	Instruction to Bidders for filling tender document	7
4	Format for Technical Bid - Annexure II	8-10
5	Checklist	11
6	General terms and Conditions-Annexure III	12-14
7	Special Terms and Conditions-Annexure IV	15-16
8	List of Approved Make of Materials/Trade	17
9	Safety Conditions of the Contract	18
10	Format for Covering Letter of submission of bid – Appendix I	19
11	Format for Letter of undertaking from the Tenderer – Appendix II	20
12	Proforma for Electronic Payment – Appendix III	21
13	Format for Pre-contract Integrity Pact to be executed on Rs.200 non judicial stamp paper – Appendix IV	22-24
14	Format for Deed of Indemnity– Appendix V	25-27
15	Format for Reciprocal Non-Disclosure Agreement – Appendix VI	28-31
PART II (Floor Plan & Drawings and Price Bid)		
16	Floor Plan and Drawings	32-33
17	Format for Price Bid /Bill of Quantities	34-41

(Sign and seal of Tenderer)

NOTICE INVITING E- TENDER from the Firms/Vendors in Civil, Plumbing and Carpentry Category for Renovation of Visiting Officers Flat at La Place Staff Quarters, Hazratganj, of Uttar Pradesh Regional Office, NABARD, Lucknow

1. NABARD invites E- tenders from Vendor / Service Providers of repute & experience to provide Civil, Plumbing and Carpentry works to undertake **Renovation of Visiting Officers Flat at La Place, Hazratganj, Uttar Pradesh Regional Office, NABARD, Lucknow.**
2. Interested Vendor / Service Providers may download the tender document from any one of these following options - NABARD's website www.nabard.org or Central Public Procurement Portal <https://eprocure.gov.in>
3. Tenderers are advised to submit e-tender (e-bids) through Central Public Procurement Portal <https://eprocure.gov.in> only. No physical copy shall be provided by NABARD or submitted to NABARD.
4. **The EMD of Rs.36,800.00/-** is required to be deposited through NEFT to the following account:

Name of Account	NATIONAL BANK FOR AGRICULTURE AND RURAL DEVELOPMENT
Name of the Bank	NABARD
Branch Name	Head Office, Mumbai
Account No (VAN) :	NABADMN18
IFSC Code:	NBRD0000002

5. MSEs as defined in MSE Procurement Policy issued by GoI or bidders who are registered with Central Procurement Organisations or empanelled with NABARD itself are exempted from submitting the EMD, a copy of the registration certificate needs to be submitted along with the Technical Bid.
6. Further, it may be noted that those Vendor / Service Providers / firms, whose technical bid will be found suitable, as per our prequalification criteria, which are given in Annexure I will only be identified for further tendering process.
7. The tenderer will be required to deposit @2% (corrected to next 100 i.e. ₹ 36,800.00) of the accepted value of tender (total value of the contract for one year), as Earnest Money Deposit (EMD). The EMD of the successful tenderer, if any, shall be adjusted towards Retention Money Deposit. The EMD Deposits of Unsuccessful bidders will be refunded.
8. Retention Money Deposit (RMD) at the rate of 5% will be recovered from each on-account bill till the total recovery amount of 5% of accepted value of the tender. While determining the RMD, the EMD already with the Bank shall be taken into account. The EMD with RMD will constitute Security Deposit. The RMD will be released after completion of Defect Liability Period of One Year and will not bear any interest. The Security Deposit will be liable to be forfeited in case the contractor commits any breach of any terms and conditions of the Contract or fails to complete the work/service.
9. The Pre-qualification criteria, format of "Technical Bid", Scope of Work, Terms and Conditions, Pre-Contract Integrity Pact and format of "Price Bid" and are enclosed with this tender document.
10. Bids, if not submitted in Bank's approved bid format shall be treated as invalid and are liable for rejection.
11. NABARD reserves the right to accept or reject any or all offers without assigning any reasons whatsoever and its decision shall be final and binding to all.

12. Further, it may be noted that those Vendor / Service Providers / firms, whose technical bid will be found suitable, as per our prequalification criteria, will only be identified for further tendering process.

Address for Communication

The Chief General Manager
National Bank for Agriculture and Rural Development (NABARD)
Uttar Pradesh Regional Office
11, Vipin Khand, Gomti Nagar
Lucknow- 226010

Sd/-
(VK Rohilla)
Dy. General Manager

उत्तर प्रदेश क्षेत्रीय कार्यालय, नाबार्ड, लखनऊ के ला प्लेस स्टाफ क्वार्टर, हजरतगंज में स्थित विजिटिंग ऑफिसर फ्लैट के नवीनीकरण के लिए सिविल, प्लंबिंग और कार्पेंटरी की श्रेणी में फर्मा/विक्रेताओं से ई-निविदा आमंत्रण सूचना

1. नाबार्ड, उत्तर प्रदेश क्षेत्रीय कार्यालय, लखनऊ के ला प्लेस स्टाफ क्वार्टर, हजरतगंज में स्थित विजिटिंग ऑफिसर फ्लैट के नवीनीकरण के लिए सिविल, प्लंबिंग और कार्पेंटरी की श्रेणी में फर्मा/विक्रेताओं से ई-निविदाएं आमंत्रित करता है।
2. इच्छुक वेंडर /सेवा प्रदाता निविदा दस्तावेज को निम्नलिखित में से किसी भी विकल्प से डाउनलोड कर सकते हैं - नाबार्ड का वेबसाइट www.nabard.org /केंद्रीय सार्वजनिक अधिप्राप्ति पोर्टल <https://eprocure.gov.in>
3. निविदाकारों को सूचित किया जाता है कि वे लिंक पर उल्लिखित प्रणालियों और प्रक्रियाओं से संबंधित अनुदेशों और ई-बोलियां प्रस्तुत करने हेतु दिए गए चरणबद्ध विवरणों (वेंडर गाइड)का ध्यान पूर्वक पालन करते हुए ई-निविदा (ई-बोली) केवल केंद्रीय सार्वजनिक अधिप्राप्ति पोर्टल <https://eprocure.gov.in> के जरिए ही प्रस्तुत करें।
5. ₹ 36,800/- का EMD एनईएफटी के जरिए निम्नलिखित खाते में जमा किया जाना अपेक्षित है:

खाते का नाम	NATIONAL BANK FOR AGRICULTURE AND RURAL DEVELOPMENT
बैंक का नाम	NABARD
शाखा का नाम	Head Office, Mumbai
खाता संख्या(VAN)	NABADMN18
आईएफएससी कोड	NBRD0000002

EMD राशि जमा करने के उपरांत, निविदाकर्ता को लेनदेन से संबंधित विवरण dpsp.lucknow@nabard.org पर ईमेल कर देना चाहिए।

6. भारत सरकार द्वारा जारी एमएसई अधिप्राप्ति नीति में यथापरिभाषित एमएसई या केंद्रीय अधिप्राप्ति संगठनों के साथ पंजीकृत बोलीकर्ताओं या स्वयं नाबार्ड के पैनल में सम्मिलित बोलीकर्ताओं को EMD जमा करने से छूट दी जाती है। इस संबंध में आवश्यक पंजीकरण प्रमाण पत्र की प्रति तकनीकी बोली के साथ संलग्न की जानी चाहिए।
7. निविदाकर्ता को निविदा के स्वीकृत मूल्य (करार के एक वर्ष के कुल मूल्य) के 2% बराबर राशि एयरनेस्ट मनी डिपॉजिट (ईएमडी) के रूप में जमा करना आवश्यक होगा। सफल निविदा दाता की ईएमडी, यदि कोई हो तो, रिटेन्शन मनी डिपॉजिट (RMD) के समक्ष संयोजित की जाएगी. असफल निविदाकर्ताओं की ईएमडी राशि वापस की जाएगी
8. प्रत्येक ऑन अकाउंट बिल से 5% की दर से रिटेन्शन मनी डिपॉजिट (RMD) वसूल की जाएगी, जब तक की टेंडर के स्वीकृत मूल्य के 5% के बराबर राशि वसूल हो जाये। आरएमडी का निर्धारण करते समय, बैंक के पास पहले से मौजूद ईएमडी को भी ध्यान में रखा जाएगा। आरएमडी और ईएमडी सब सिक्यूरिटी जमा का हिस्सा होंगे। आरएमडी/ईएमडी को एएमसी अवधि की संतोषजनक समाप्ति से एक वर्ष की दोष दायित्व अवधि के बाद जारी किया जाएगा और इस पर कोई ब्याज देय नहीं होगा। यदि ठेकदार अनुबंध के किसी भी नियम और शर्त का उल्लंघन करता है या काम/सेवा को पूरा करने में विफल रहता है तो सिक्यूरिटी डिपॉजिट जब्त करने के लिए उत्तरदायी होगा।
9. अर्हता-पूर्व मानदंड, तकनीकी बोली का फॉर्मेट, काम का दायरा, नियम व शर्तें, संविदा पूर्व इंटीग्रिटी पैक्ट और मूल्य बोली का फॉर्मेट इस निविदा दस्तावेज के साथ संलग्न है।
10. ई- निविदाएँ यदि बैंक के अनुमोदित निविदा फॉर्मेट में नहीं दी गई तो उन्हे अमान्य माना जाएगा और निरस्त कर दिया जाएगा।

11. किसी भी या सभी बोलियों को बिना कोई कारण बताए स्वीकृत/अस्वीकृत करने के लिए नाबार्ड के पास अधिकार सुरक्षित रहेगा और नाबार्ड का निर्णय अंतिम तथा सर्वमान्य होगा ।

12. इसके अलावा, यह ध्यान दिया जाना चाहिए कि वे विक्रेता / सेवा प्रदाता / फर्म, जिनकी तकनीकी बोली हमारे पूर्व योग्यता मानदंडों के अनुसार उपयुक्त पाई जाएगी, केवल उन्हें ही आगे की निविदा प्रक्रिया के लिए पहचाना जाएगा

संपर्क के लिए पता

मुख्य महाप्रबंधक
राष्ट्रीय कृषि और ग्रामीण विकास बैंक
उत्तर प्रदेश क्षेत्रीय कार्यालय
11, विपिन खंड, गोमती नगर
लखनऊ-226010

हस्ता./-
(वी के रोहिल्ला)
उप महाप्रबंधक

Annexure- I

PRE-QUALIFICATION CRITERIA

1. The contractors should meet following qualification criteria:

(1.1) Minimum 7 years' experience (as on 31.03.2023) in the field of similar works (work in and should have at least one of the qualifying works carried out for Public Sector Undertakings (PSUs)/Banks/Govt. Office.

(1.2) The bidders should have carried out similar works during last 7 years (ending 31.03.2023) with annual contract value (costing individually) not less than the amount as given in following table:

SN	Experience Criteria	(Rs. Lakh)
1	1 similar work during last 7 years (ending 31.03.2023) with annual contract value (costing individually) not less than Rs. >>>>	14.69 lakh
	OR	OR
2	2 similar works during last 7 years (ending 31.03.2023) with annual contract value (costing individually) not less than Rs. >>>>	9.18 lakh
	OR	OR
3	3 similar works during last 7 years (ending 31.03.2023) with annual contract value (costing individually) not less than Rs. >>>>	7.34 lakh

2. The tenderers should have Annual Turnover as given in the following table during the last three years ending **31 March 2023** supported with audited balance sheets/ profit & loss statement or a registered Chartered Accountant certified statement of accounts.

S.N	Turn over Criteria	(Rs. Lakh)
1	Average Annual Turnover during last three years ending 31.03.2023 should be at least	Rs.5.50 lakh

3. The tenderer should have their own office within the city / suburban areas of Lucknow
4. Contract will be given to the tenderer who has their registered own office within the city/ suburban areas of Lucknow and are able to establish the same fact. Tenderers failing to establish their registered office in Lucknow will be summarily rejected.
5. Tender shall be accompanied by a copy of each of the documents like,
- Proprietorship Firm/Partnership Firm/Company Registration Certificate
 - MSME Registration Certificate
 - Registration under Contract Labour Act/Labour Department
 - Articles of Association/Memorandum of Association/ partnership deed/ any other relevant document showing composition of the firm
 - List of eligible work executed during last seven years
 - PAN
 - GSTN Registration
 - Employee State Insurance Act Registration Certificate
 - PF Registration Certificate
 - **Statements of Income Tax Returns of past 03 Financial Years ending on 31.03.2023**
 - Particulars of bankers & Bank account details.
 - Details of work experience shall be supported by work orders and corresponding completion certificates.

- The client-wise names of similar work(s), year(s) of execution of work (s) awarded, and actual value of executed work(s), reasons for delay (if any), names and full contact details of the officers/ authorities/ departments under whom the work(s) was/were executed should be furnished in the prescribed format.
 - Details of works on hand
6. Audited final accounts of the business of the contractor for last 3 years duly certified by a Chartered Accountant/certificate of turnover issued by a Chartered Accountant should be enclosed in proof of their credit worthiness and turnover for the last three years.
 7. If required, original certificates shall be produced for verification by the tenderer and will be returned after verification.
 8. The tenderers should have applicable Tax registrations (PAN, GSTN TIN, TAN, etc.) and also registration with Labour Department, Provident Fund, ESIC, etc., supported with documentary evidence and licenses, permissions, approvals issued by Labour enforcement and other statutory authorities, wherever applicable.
 9. Tenderers should have a Current Bank Account with a scheduled commercial bank.
 10. Tenderers should submit Pre-contract Integrity Pact to be executed on Rs.200 non judicial stamp paper.
 11. NABARD reserves the right to verify any or all the documents furnished by the Tenderers with any authorities. NABARD also reserves the right to cancel any or all the applications without assigning any reason thereof.
 12. Intending applicants are required to furnish details about their firm/organization, experience, competence, etc.
 13. The application form should be signed by a person on behalf of the Firm/Organization, who is duly authorized to do so.
 14. If the space in the application form is insufficient for furnishing full details, such information should be supplied on a separate sheet duly signed by competent authority
 15. Applications containing false or inadequate information are liable for rejection and Bank reserves the right to blacklist those agencies.
 16. The staff deployed by the firm at site should have adequate experience and knowledge in their respective works.
 17. The firms which do not fulfil prequalification criteria shall not be considered for selection and award of work.

(Signature and Seal of the Tenderer)

Instructions for filling the tender

1. All the pages of the Tender Document shall be signed and sealed by the Tenderer.
2. NABARD takes no responsibility for delay/non submission/ non uploading of Quotations/ Tender Documents on the website for whatsoever reasons.
3. The last date of receipt of Tender is on or before 15.00 hours on 15.03.2024 and Bids will be opened at 15.30 hours on 16.03.2024 at 15.30 hrs. Revision in date and time, if any, would be conveyed.
4. Bids submitted by unauthorised agents and FAX/Telegraphic bids shall not be entertained/ considered.
5. Rates should include all items pertaining to the captioned work in the Residential Premises at La Place, Hazrat Ganj, Lucknow, Uttar Pradesh as mentioned in the tender and unless the same is done to the satisfaction of the NABARD, the bill will not be accepted.
6. Rates should be filled in the Tender neatly and no overwriting shall be made. Corrections, if any shall be authenticated by subscribing signature of the tenderer. The rates quoted should be written legibly in words and figures. If on check, differences are observed between the rates given by the Contractor in words and figures or in the amount worked out by him, the following procedure shall be followed.
 - 7.1 When the amount of an item is not worked out by the Contractor or it does not correspond with the rate written either in figures or in words, then the rate quoted by the Contractor in words shall be taken as correct.
 - 7.2 When the rates quoted by the Contractor in figures and in words tallies, but the amount is not worked out correctly, the rate quoted by the Contractor shall be taken as correct and not the amount.
7. When there is a difference between the rates in figures and in words the rate that corresponds to the amounts worked out by the Contractor shall be taken as correct.

DECLARATION BY THE CONTRACTOR

I/ We have read and understood all the instructions / conditions made above and I/ We have taken into account the above Instructions / Terms and Conditions while quoting the rates. I/ We accept all the above Terms and Conditions without any reservation, in all respects.

Place :

Date:

(Signature and Seal of the Tenderer)

Annexure- II
FORMAT OF TECHNICAL BID

(A) Name of the firm and Composition of the Firm	
(Full particulars (whether the Tenderer is an individual /Proprietorship Firm partnership firm / company etc.) of the composition of the firm of Tenderers in detail should be submitted along with the name(s) and address(es) of the partners, copy of the Articles of Association /Power of Attorney/ any other relevant document.)	
(a.1) Registered Head Office Address	
(a.2) Local Office Address	
(a.3) Year of establishment/Registration and Act under which registered	
(B) Work Experience (Details of work experience supported by work orders indicating the value & general specification of work, No. of persons to be engaged as per agreement, other documents and certificates. The details along with documentary evidence of previous experience, if any, of carrying out works for NABARD/ Public sector banks/ Government department/ Semi Govt. department/ Other Public Sector Undertakings/ private banks at any other Centre should also be given.)	
(C) Credit worthiness of the Tenderer & Turnover during the specified period (Copies of IT deposit certificates (such as copy of deposited Form 16 or any such other certificate) along with latest final accounts of the business of the Tenderer duly certified by a CA should be enclosed in proof of their credit worthiness and Turnover for the last three years ending 31.03.2023.)	
(D) Name(s) and address(es) of the Bankers and their present contact executives (Written information about the names and address of their bankers along with full details like names, postal address, e- mail IDs, telephone (landline & mobile No.s), Fax No. etc of the contact executive (i.e. The persons who can be contacted at the office of their bankers by the Bank, in case it is so needed) should be furnished.)	
(E) Details of Bank accounts (Full particulars of their bank accounts, account No., type of account, account opening date etc. should be furnished.)	
(F) Name(s) and address(es) of the Clients and their present Executives (Written information about the names and address of their clients along with full details like	

names, postal address, e- mail IDs, telephone (landline & mobile No.s), Fax No. etc. of the contact executive (i.e. The persons who can be contacted at the office of their Clients by the NABARD, in case it is so needed) should be furnished.)	
(G) Litigation & civil suits (The Tenderer should furnish details of his involvement in any type of litigation with any of his present or past clients. He should also furnish the details of any civil suits pending against him or his workmen in any court of law.)	
(H) Whether registered with the Registrar of companies/ Registrar of firms. If so, mention number and date and attach a copy of registration	
(I) Details of Registration with Provident Fund, Labour Authorities, ESIC, if any.	
(J) Whether registered for GSTN/ service tax purposes. If so, Also furnish relevant copies.	
(K) Whether registered in the panel of other banks and other financial institutions and if yes, furnish the details of registration viz. names, category and date of registration, etc.	
(L) MSME Registration Certificate, if applicable	
(M) Copy of pre contract Integrity Pact	

Details of Key Administrative Personnel

SI.No.	Name	Designation	Qualification	Professional Experience	No. of years associated with the firm

PREVIOUS EXPERIENCE

List of important works executed by the firm during last 7 years with experience in executing works of nature. Please arrange to provide value of job, approximate area of each contract where similar work was/ is being undertaken along with copy of work orders, performance certificates/completion certificates.

Tenderers are encouraged to apply only if they have experience in similar work nature.

Ser	Name of the work And Location	Nature of Work	Name & full postal address of the owner	Contract Amount (Rs)

ii) List of important **works on hand** costing Rs.10.00 lakh and above with experience in executing similar work.

S.No	Name of the work And Location	Nature of Work	Name & full postal address of the owner	Contract Amount (Rs)

Experience of Works Personnel

1. List of Civil, Interior Furnishing, Plumbing Personnel, giving details about their academic/technical qualifications, experience, etc. including that in the applicant's organization. (Please attach extra sheets if required).

S.No.	Name	Age	Qualification	Experience	Nature of works handled	Date from which employed in the organization	Any other relevant information

2. **List of available tools, Equipment.** (Please attach extra sheets if required).

S.No.	Name of tools/ Equipment and Accessories	Total No. of units	No. of units can be spared for NABARD's work
(1)	(2)	(3)	(4)

3. Indicate other points, if any, to show applicant's technical and managerial competency to indicate any important point in applicant's favour.

4. No. of supplementary sheets attached

Declaration by the Contractor

I/ We have read and understood the Scope of Work and special terms and conditions for undertaking **Renovation of Visiting Officers Flat at La Place, Hazratganj, Uttar Pradesh Regional Office, NABARD, Lucknow** as indicated and I/ We have taken into account the above while quoting the rates. I/ We accept all the above points without any reservation from our/ my side, in all respects. Further, I/ We also declare that no prohibitive things/ banned chemicals will be used, which are harmful to human life.

Place :

Date :

(Signature of the Tenderer with Name, Seal & Date)

CHECK-LIST FOR TECHNICAL BID

SER	Documents asked for	Whether Submitted or Not
1	A) Bid Security, if applicable of Rs. (Rupees in words) in the form of e-payment	
2.	One self-attested recent passport size photograph of the Authorized person of the firm/agency, with name, Designation, address and office telephone numbers. If the bidder is a company/ partnership firm, name designation, address and office telephone numbers of Directors/Partners also.	
3.	Undertaking on own Letter-Head as per format prescribed	
4.	Self-attested copy of the PAN card with copy of cancelled cheque for KYC compliance.	
5.	Self-attested copy of GSTIN Registration	
6.	Self-attested copy of valid Registration number of the Firm /agency.	
7.	Valid Contractor License issued by Government of Uttar Pradesh	
8.	Self-attested copy of valid Employees Provident Fund Registration number.	
9.	Self-attested copy of valid ESI Registration No.	
10.	Self-attested copy of valid License No. under Contract Labour (R&A) Act, 1970.	
11.	Proof of experiences of last seven financial years as specified in the NIT along with satisfactory performance certificates from the concerned employers	
12.	Annual returns of previous three years supported by audited balance sheet for FY 2022-23, 2021-22, and 2020-21.	
13.	Signed and scanned Copy of Pre Contract Integrity Pact mentioned Appendix-IV on Rs. 200 Stamp Paper. (hard copy to be attached with Technical Bid)	

(Signature of the Tenderer with Name, Seal & Date)

Annexure- III

General Terms and Conditions

1. Contractors are advised to visit the site and thoroughly understand the nature and scope of the works and be familiar with the site conditions before quoting.
2. The quantities indicated in the BOQ are tentative and shall be executed at the sole discretion of NABARD.
3. Quoted rates should be workable and reasonable and should include incidental and all overheads and profits. The contractor should furnish Rate Analysis for scrutiny of the rates by NABARD, if required.
4. Rates should include all Taxes, Duties, Levies, Wages as per Act, etc. and should be firm for the entire Contract period. No escalation of rates will be allowed for the entire contract period on any account.
5. Materials used should conform to relevant BIS norms.
6. Specifications and Method of Measurements shall be followed as applicable. However, in the absence of the same and/ or in case of any discrepancy, the decision of CGM, NABARD, Uttar Pradesh Regional Office, Lucknow will be final.
7. The items not covered in the Schedule of Quantities of the Contract Document shall be paid as per Rate Analysis based on the market prices supported by documentary proof with 15% towards Contractor's OHP (which include IT and GST) as applicable. The Rate Analysis shall be submitted by the Contractor for scrutiny and approval of NABARD.
8. Income Tax, GST and other taxes etc. as applicable will be deducted from total payment due to the Contractor.
9. The Contractor should have valid License relating to his Contract and the workmen employed by the Contractor should also have the valid License and/or experience in their trade.
10. The Contractor should arrange to obtain necessary insurance cover (Workmen compensation policy) for his employees at his cost and should be responsible for the safety of persons, employed by him.
11. All the Standard Conditions of the Contract shall be binding on the parties as per Indian Contract Act and prevailing Rules.
12. The entire work is required to be completed as specified in the tender.
13. The Contractor shall comply with the provisions of Contract, Labour (Regulation & Abolition) Act, 1970, Minimum Wages Act and all other Labour Laws and other Statutory Regulations (both Central and State) that may be enforced from time to time by the appropriate authorities. NABARD shall not be held responsible for any penalty on failure of the any Labour Regulations. NABARD shall have the power to inspect the Wage Register and for physical verification of salary paid to the staff with reference to any records of the Contractor and to insist the Contractor to comply with Laws.
14. The Contractor should be responsible to fulfill all the obligations in connection with the workers employed by the Contractor for the purpose of the Contract and all the Statutory and other liabilities, if any, including minimum wages, leave salary, uniform, ex-gratia, gratuity, ESI, Provident Fund, Workman Compensation, if any, etc. in connection therewith shall be on the Contractor's account and payable by the Contractor.
15. The Contractor should obtain necessary permission that may be required for the purpose of this Contract from such authorities as may be prescribed by Law from time to time.
16. The Contractor or his authorised representative should visit the site frequently as required by NABARD and meet NABARD's Engineer/concerned officers with prior appointment for any clarifications and to receive instructions, take measurements, etc. at the site.

17. The contractor should engage a qualified technical personnel/supervisor to supervise the work on daily basis as per the specifications and instruction of the Bank.
18. The Contractor shall be fully responsible and shall compensate NABARD in the event of any damage to staff or material, injury/ damage or death as the case may be, caused directly or indirectly due to the negligence of the Contractor or his agents and/ or his employees, or workmen. NABARD will not be liable to pay any compensation to the personnel deployed by the contractor for sustaining any injuries while discharging the duties in the premises.
19. The Contractor shall indemnify the Employer against any losses as per format given at Appendix VI.
20. Any act of indiscipline / misconduct / theft / pilferage on the part of any employee engaged by the Contractor resulting in any loss to NABARD in kind or cash will be viewed seriously and NABARD will have the right to claim damages or levy fine and/or terminate the Contract forthwith, if necessary.
21. In case of any default or failure on Contractor's part to comply with all/ any one of the Terms/ Conditions, Chief General Manager, NABARD, Uttar Pradesh Regional Office, 11, Gomti Nagar, Lucknow reserves to himself the right to take necessary steps to remedy the situation including, inter-alia, the deduction of appropriate amount/s from dues otherwise payable to Contractor and/ or by taking recourse to appropriate recovery proceedings.
22. If any dispute arises on any matter concerning this Contract, the decision of CGM, NABARD, UP RO, Lucknow shall be final and binding.
23. The Contractor should not at any time do, cause or permit any nuisance on the site / do anything which shall cause unnecessary disturbances or inconvenience to the occupants/visitors at site or near the site of work.
24. The contractor by his own expenses and risk shall uninstall relevant fixtures in the area of work carefully and without any damage, to a convenient place under intimation to the Bank for the convenience of work, and shall reinstall the same, wherever required, after completion of the work.
25. The work should be carried out with least inconvenience to the occupants. The workmen employed by the Contractor should abide by the Rules and Regulations maintained by NABARD in the premises, especially in respect of working hours, entry of the workers to the premises, interpersonal relation with the occupants etc.
26. The Contractor should obtain approvals, if any, necessary for the work from the statutory bodies on behalf of NABARD. The contractor shall ensure that all COVID 19 related protocols as per the directions of State/ Central Govt. are strictly complied with the workmen/ labour.
27. The Contract can be terminated by NABARD on 07 days' notice if services are found to be unsatisfactory and if there is no improvement even after issue of three notices to the contractor.
28. On-site storage space will be provided to the Contractor subject to availability. However, the Contractor may erect temporary sheds for storage purposes at his cost with the permission of NABARD. NABARD will not be responsible for Contractor's materials. The Contractor may be required to vacate the storage space and sheds as per exigency without any extra cost to NABARD. All the stores and equipment shall be removed from the project site after thorough cleaning of the same, within 15 days of completion of the work. A penalty deduction of Rs. 1000/- per week could be levied if not complied. The stores and equipment if not lifted even after 30 days of completion of work, will be lifted by the bank and the cost incurred along with an additional penalty of Rs. 1000/- shall be charged upon the Contractor.
29. The Contractor shall provide everything necessary for the proper execution of the works. NABARD will not supply any 'T&P' and materials or any other equipment, materials, labour, etc. and no payment in this respect will be made by NABARD. The Contractor shall supply, and maintain all the scaffoldings, jhulla, T&P etc. at his cost during the execution of any work and remove them as soon as the work is completed.
30. The Contractor shall not directly or indirectly transfer, assign or sublet the Contract or any part of it, without written permission of NABARD.

31. Any defect which may appear within the Defect Liability Period after the Virtual completion of work should be rectified by the Contractor at his cost and only thereafter the RMD will be refunded to the Contractor.
32. Security Deposit: Retention Money Deposit (RMD) shall be deducted @ 5% of the value of work done from every bill and shall be refunded after expiry of defects liability period of **one year** after the date of virtual completion of the work provided the Contractor has satisfactorily carried out all the rectification works and attended to all defects to the satisfaction of NABARD. No interest will be paid on Retention Money Deposit. No mobilization advance will be given to contractor.
33. Defects Liability Period: **One year** from the date of Virtual Completion of works certified by NABARD.
34. Validity of Tender Rates: 90 days from the date of opening of Technical Bid (Part-1).
35. Liquidated Damages: 1% of the accepted Tender Value per week or part of the week subject to maximum of 10% of the value of work.
36. The contractor shall be entitled to receive payments on submission of interim bills of amount more than Rs.10.00 lakh only during execution of work. The contractor shall submit interim bills only after working out the appropriate measurements jointly recorded with NABARD at site in the Measurement Book (MB). This is not only to regulate correctness of quantity but also to facilitate expeditious clearing of the bills. The interim bills submitted by the contractor will be paid by NABARD after all the statutory deductions viz. RMD @ 5%, GST, TDS and any other taxes/charges as applicable.
37. Termination of agreement: "If the services of the contractor are not found to be satisfactory or for any other reason considered by NABARD as insufficient, the contractor will be given a notice, with a **notice period of 07 days**, to improve his services. If the contractor fails to improve his services within the Notice period, NABARD shall have the discretion to terminate the contract either in part or in whole, on any day after the expiry of the said notice period if
- in the opinion of the Bank (which shall not be called in question by the contractor and shall be binding on the contractor) the contractor fails or refuses to implement this agreement to the Bank's satisfaction and/or
 - the contractor commits a breach of any terms and conditions of this agreement and/or
 - the contractor is adjudged an insolvent or a compromise is entered by him with his creditors or if distress or execution or other process is levied upon or receiver is appointed for any part of the assets or property of contractor and/or
 - for any reason whatsoever, the contractor becomes disentitled in law to perform his obligations under this agreement and/or
- there is any variation in the ownership/partnership or management of the contractor or his business without the prior approval in writing of the Bank to such variation.
The Contractor shall not be entitled to any compensation for such termination.
38. On expiry or early termination of the contract, the personnel engaged shall vacate the said premises without any way causing any damage to the premises and the property therein.
39. The successful tenderer shall be required to submit 'Deed of Indemnity' and 'Reciprocal Non-Disclosure Agreement' which shall be executed on a non-judicial stamp paper of Rs.500/- and Rs.200/- respectively. The proforma of the same is given in Appendix V and VI.
40. We accept all the above Terms and Conditions in all respects without any reservation.

(Signature of the Tenderer with Name, Seal & Date)

Annexure- IV

SPECIAL TERMS AND CONDITIONS

1. The Tender is strictly on Item Rate basis.
2. All the pages of the Tender Document shall be signed by the Tenderer.
3. NABARD takes no responsibility for delay / loss in post or non-receipt of Tender Documents.
4. Bids submitted by un-authorized agents and by FAX shall not be entertained / considered.
5. Tenderers are advised to visit the site at their cost, conduct survey of existing conditions so as to familiarize themselves with the site conditions, nature of works etc. and get all clarifications as necessary from NABARD before quoting the rates.
6. Tenderer should make necessary arrangements to ensure removal of debris out of office premises to the safe limit and cleaning of the site thoroughly after work completion, and unless the same is done to the satisfaction of the NABARD's Engineer/concerned officers, the final payment will not be made to the vendor.
7. The Contractor shall make necessary arrangement for watch and ward of his materials, tools, machines etc. stored for the execution of the work at his own risk and cost and NABARD will not be responsible on any account.
8. If the last date of receipt of Tender is a holiday, then submission of Tenders shall be shifted to next working day without change of time and venue.
9. The Tenderers should quote their rates strictly adhering to Terms and Conditions stipulated in the Tender Document. Unsolicited correspondence after opening of the Tender shall not be entertained. Conditional / deviational tenders may be rejected without making any reference to the Tenderers.
10. No Tenderer will be allowed to withdraw his Tender during the validity period. Subletting of the Contract is not permitted.
11. Rates should be filled in the Tender neatly and as far as possible, no correction shall be made. The rates quoted should be written legibly in words and figures. If on check, differences are observed between the rates given by the Contractor in words and figures or in the amount worked out by him, the following procedure shall be followed-
 - a. When there is a difference between the rates in figures and in words, the rates which corresponds to the amounts worked out by the Contractor shall be taken as correct.
 - b. When the amount of an item is not worked out by the Contractor or it does not correspond with the rate written either in figures or in words, then the rate quoted by the Contractor in words shall be taken as correct.
 - c. When the rates quoted by the Contractor in figures and in words tallies, but the amount is not worked out correctly, the rate quoted by the Contractor shall be taken as correct and not the amount.
12. No advance shall be paid towards mobilization and cost of materials.
13. The contractor at his cost and risk should shift/displace the Bank's furniture, fixtures etc. as per the needs to facilitate the job during the time of work and should re-shift the goods at its initial place without any damage.
14. The Contractor shall use necessary safety equipment and maintain all safety measures during the execution of works and ensure compliance of Safety Code as per Rules and Regulations in force.
15. **The contractor shall obtain permission from Residential society for use of lift for carrying goods and construction material.**
16. The Contractor shall submit the bills along with the accepted and jointly recorded measurement sheets duly certified by the NABARD's Engineer/concerned officers.

17. The Contractor should have necessary Contract License and comply with the Labour Laws as applicable.

18. Notwithstanding anything stated above, NABARD reserves the right to assess the Tenderer's capability and capacity to perform the contract, should the circumstances warrant such assessment in the overall interest of NABARD.

19. The decision of NABARD in awarding the work shall be final and cannot be subjected to arbitration.

20. NABARD reserves the right to accept/ negotiate / reject any Tender either in whole or in part without assigning any reasons therefore whatsoever and without entering into any further correspondence and hence, NABARD shall be under no obligation to accept the lowest or any other Tenders received in response to this Tender. The decision of NABARD in this regard shall be final and undisputable.

21. Any disputes or differences of any kind whatsoever which shall at any time arise between the parties hereto touching or concerning the works or the execution or maintenance thereof this contract or effect thereof or to the rights or liabilities of the parties or arising out of or in relation thereto whether during or after determination foreclosure or breach of the contract (other than those in respect of which the decision of any person is by the contract expressed to be final and binding) shall after written notice by either party to the contract to the other of them be referred for adjudication to a sole Arbitrator to be appointed provided as per Arbitration & Conciliation Act, 1996. The arbitration shall be conducted by sole arbitrator appointed by NABARD and the award of the Arbitrator shall be final and binding on the both the parties. The venue of the arbitration shall be Lucknow and language for the same shall be English or Hindi.

The Employer and the contractor hereby also agree that arbitration under clause shall be condition precedent to any right to action under the contract with regard to the matters hereby expressly agreed to be so referred to arbitration.

DECLARATION BY THE CONTRACTOR

I/ We have read and understood all the instructions/ conditions made above and I/ We have taken into account the above Instructions /Terms and Conditions while quoting the rates. I/ We accept all the above Terms and Conditions without any reservation, in all respects.

Place:

(Signature of the Tenderer)

Date:

Name and Seal:

LIST OF APPROVED MAKE OF MATERIALS / TRADE

1. Unless otherwise mentioned any one of the approved makes or brands shall be allowed to be used. Other specific equivalent brands with BIS mark may be allowed to be used if approved by NABARD.
2. The tenderer shall distinctly understand that it will not be their prerogative to insist on a particular brand from the list. Final selection will be done with the approval of NABARD.
3. Wherever contractor proposes to use equivalent makes (i.e. other than specified), the same shall be done after prior approval of the Employer. Any additional expenditure and time due to this shall be solely on contractor's account and no claims whatsoever shall be entertained in this regard.

If the schedule of quantities prescribes a particular brand of materials or fittings, the same shall be considered while quoting the rates.

(Signature of the Tenderer)

Name and Seal:

SAFETY CONDITIONS OF THE CONTRACT

1. Consumption of alcohol, smoking and chewing pan/masala/gutkha are strictly prohibited in the Office premises.
2. The personnel deployed by the contractor can use common facilities for drinking water and toilet provided at the premises. However it should be ensured that same should be kept clean at all times.
3. The contractor must conform to and ensure all necessary safety requirements for their labour which must be ensured invariably at all the times without any deviation. NABARD will not be held responsible in any way for any unforeseen incident/accident that may occur during the work undertaken.
4. The contractor shall be responsible for all injury to persons, and for all structural and decorative damage to property which may arise from the operation or neglect of contractor or their staff or damages arising from carelessness, accident or any other cause whatsoever in any way connected with carrying out of the contractor. The contractor shall indemnify the Bank and hold it harmless in respect of all and any such injury or damages to persons or property as aforesaid and also in respect of any claim made in respect of injury or damages under Acts of Government or otherwise and also in respect of any Award of compensation of damages consequent upon such claims.
5. The Contractor shall maintain in a readily accessible place first aid appliances including adequate supply of sterilised dressings and cotton wool.
6. An injured person shall be taken to a public hospital without loss of time, in cases where the injury necessitates hospitalisation.
7. It is entirely the responsibility of the contractor to follow the safety procedures such as using safety belts, life lines, helmets, rubber gloves etc. depending upon the nature of works Contractor is free to approach NABARD for any suggestion in this regard. However any lapse in this regard will be viewed seriously.
8. A penalty of Rs.1000.00 per instance shall be levied for violation of safety norms including non-use of personal protective equipment. A penalty of Rs.2000.00 per instance shall be levied if violation is repeated.
9. Penal action will also be taken if the contractor's supervisors and workmen do not wear the uniforms and photo identity cards issued by the contractor and thus pose a security risk to the safety of the Bank's establishments, its officers and the families of its officers residing in flats. The decision of the Bank in all such cases attracting penalties shall be final and binding on the contractor.
10. An adequate insurance coverage shall be arranged by the contractor for all employees/workmen against accident, and the Bank shall not be responsible for any liability arising out of any accident/injury caused to the employees/workmen while executing the work.
11. The Bank shall be at liberty and is hereby empowered to deduct the amount of any damages compensation, cost charges and expenses arising or accruing from or in respect of any such claim or damages from any or all sums due or to become due to the contractor.

Declaration by the Contractor

I/ We have read and understood the Safety code for the **Renovation of Visiting Officers Flat at La Place, Hazratganj, Uttar Pradesh Regional Office, NABARD, Lucknow** and I/ We have taken into account the above while quoting the rates. I/ We accept all the above points without any reservation from our / my side, in all respects.

(Signature of the Tenderer with Name, Seal & Date)

Appendix-1

(Covering Letter by the Tenderer for Submission of BID)

(To be submitted in Tenderer's own Letter head)

Ref. No.

Date:

To

The Chief General Manager /Officer in Charge
National Bank for Agriculture and Rural Development (NABARD)
Uttar Pradesh Regional Office
11, Vipin Khand, Gomti Nagar,
Lucknow, Uttar Pradesh -226010

Dear Sir,

Submission of Bid for undertaking **Renovation of Visiting Officers Flat at La Place, Hazratganj, Uttar Pradesh Regional Office, NABARD, Lucknow.**

With reference to NABARD, UP RO's Tender Notice dated 2024,

I/ We offer our services for **Renovation of Visiting Officers Flat at La Place, Hazratganj, Uttar Pradesh Regional Office, NABARD, Lucknow.**

I/We understand that NABARD reserve the right to accept or reject any or all the tenders either in full or in part without assigning any reason therefor.

I/We also agree that our tender will remain valid for acceptance by the Bank for 90 days from the date of opening of price bid of the tender and this period of validity can be extended for such period as may be mutually agreed between the Bank and us in writing.

All the desired information in the prescribed format i.e. format of technical bid, price bid documents and other certificates as required by NABARD, are enclosed herewith for NABARD's perusal.

Thanking NABARD

Yours faithfully,

(Signature of Authorized person on behalf of the Firm/ Agency/ Tenderer)

(Tenderer's Seal)

Appendix- 2

(Letter of Undertaking from the Tenderer)

(To be submitted in Tenderer's own Letter head)

To,
The Chief General Manager
National Bank for Agriculture and Rural Development (NABARD)
Uttar Pradesh Regional Office
11, Vipin Khand, Gomti Nagar,
Lucknow, Uttar Pradesh -226010

Dear Sir,

1. Submission of Bid for undertaking **Renovation of Visiting Officers Flat at La Place, Hazratganj, Uttar Pradesh Regional Office, NABARD, Lucknow**

2. I / We have examined the Scope of Works, Specifications and Schedule of Quantities and Terms and Conditions relating to the Tender for the said works after going through the tender document published by NABARD, UP RO.

3. I / We have visited the concerned area where **Renovation of Visiting Officers Flat at La Place, Hazratganj, Uttar Pradesh Regional Office, NABARD, Lucknow** is going to take place and acquired the requisite information relating thereto as affecting the Tender.

4. I / We hereby offer to execute and complete the works in strict accordance with the Tender Document at the item rates quoted by me/ us in the attached Bill of Quantities in all respects as per the Specifications and Scope of Works described in the Tender Document and the Annexures containing Terms and Conditions.

5. I/We agree to deposit all taxes, levies, Cess etc., on account of service rendered by me to NABARD, to the concerned tax collection authorities from time to time as per extant rules and regulations on the matter.

6. I/We agree to pay all Government (Central and State) Taxes such as Income Tax, Surcharge, Cess, GST, etc. and other taxes prevailing from time to time. The rates will be exclusive of all taxes (The payment shall be subject to TDS and taxes as applicable at the time of payment) and valid for the currency of the contract. Even if the contracts are extended, the rates will not be changed by us.

7. I /We further agree to pay any fine or statutory dues imposed by any statutory authority in course of execution of subject contract, for which the tender is being submitted.

8. The rates quoted by me/us, are firm and shall not be subjected to variations on account of fluctuation in the market rates, taxes or any other reasons whatsoever for the captioned period.

9. I/ We hereby certify that all the statements made and information supplied in the tender document and accompanying statements are true and correct.

10. Should this Tender be accepted, I/we hereby agree to abide by and fulfil all the Terms and Conditions and Provisions of the Contract Document.

Yours faithfully,

Place:
Date:

(Name and signature of the tenderer)

Appendix-3

(PROFORMA FOR ELECTRONIC PAYMENT)

Details of Bank account to be furnished by the contractor/ service provider for effecting payment by NABARD.

1	Name of the account holder (As appearing in the Bank account)	
2	Address of the Account Holder	
3	Name of the Bank	
4	Name of the Bank Branch	
5	Account number	
6	RTGS/ NEFT/ IFS Code	
7	Type of account	
8	PAN Number	
9	GSTIN Number	
10	Email id	
11	Contact Number	

Signature and Seal:

Please attach the following:

- (1) Photocopy of one cancelled cheque leaf of the Bank account;
- (2) Copy of PAN card;
- (3) Allotment letter / registration letter under GSTIN.

Appendix-4

(PRE-CONTRACT INTEGRITY PACT)

(To be submitted on RS.200 Stamp Paper only on first page and remaining document on normal A4 size pages duly signed by the bidder)

Between

**NATIONAL BANK FOR AGRICULTURE AND RURAL DEVELOPMENT (NABARD), Uttar Pradesh
Regional Office hereinafter referred to as “The Principal”**

And

..... hereinafter referred to as “The Bidder”

Preamble

The Principal intends to award, under laid down organizational procedures contract/s for **Renovation of Visiting Officers Flat at La Place, Hazratganj, Uttar Pradesh Regional Office, NABARD, Lucknow** The Principal values full compliance with all relevant laws of the land, rules, regulation and economic use of resources and of fairness /transparency in its relations with its Bidder(s).

In order to achieve these goals, the Principal will appoint Independent External Monitors (IEMs) who will monitor the tender process and the execution of the contract for compliance with the principles mentioned above.

Section 1 – Commitments of the Principal

The Principal commits itself to take all measures necessary to prevent corruption and to observe the following principles: -

- a. No employee of the Principal, personally or through family members, will in connection with the tender for, or the execution of a contract, demand, take a promise for or accept, for self or third person, any material or immaterial benefit which the person is not legally entitled to.
- b. The Principal will, during the tender process treat all Bidder(s) with equity and reason. The Principal will, in particular, before and during the tender process, provide to all Bidder(s) the same information and will not provide to any Bidder(s) confidential / additional information through which the Bidder(s) could obtain an advantage in relation to the tender process or the contract execution.
- c. The Principal will exclude from the process all known prejudiced persons.
- d. If the Principal obtains information on the conduct of any of its employees which is a criminal offence under the IPC/PC Act, or if there be a substantive suspicion in this regard, the Principal will inform the Chief Vigilance Officer and in addition can initiate disciplinary actions.

Section 2 – Commitments of the Bidder(s)

The Bidder(s) commit themselves to take all measures necessary to prevent (s) corruption. The Bidder commit themselves to observe the following principles during participation in the tender process and during the contract execution:

- a. The Bidder(s) will not, directly or through any other person or firm, offer, promise or give to any of the Principal’s employees involved in the tender process or the execution of the contract or to any third person any material or other benefit which he/she is not legally entitled to, in order to obtain in exchange any advantage of any kind whatsoever during the tender process or during the execution of the contract.
- b. The Bidder(s) will not enter with other Bidders into any undisclosed agreement or understanding, whether formal or informal. This applies in particular to prices, specifications, certifications, subsidiary contracts, submission or non-submission of bids or any other actions to restrict competitiveness or to

introduce cartelization in the bidding process.

c. The Bidder(s) will not commit any offence under the relevant IPC/PC Act; further the Bidder(s) will not use improperly, for purposes of competition or personal gain, or pass on to others, any information or document provided by the Principal as part of the business relationship, regarding plans, technical proposals and business details, including information contained or transmitted electronically.

d. The Bidder(s) of foreign origin shall disclose the name and address of the Agents/representatives in India, if any. Similarly the Bidder(s) of Indian Nationality shall furnish the name and address of the foreign principals, if any.

e. The Bidder(s) will, when presenting their bid, disclose any and all payments made, is committed to or intends to make to agents, brokers or any other intermediaries in connection with the award of the contract.

f. Bidder(s) who have signed the Integrity Pact shall not approach the Courts while representing the matter to IEMs and shall wait for their decision in the matter.

The Bidder(s) will not instigate third persons to commit offences outlined above or be an accessory to such offences.

Section 3 – Disqualification from tender process and exclusion from future contracts

If the Bidder(s), before award or during execution has committed a transgression through a violation of Section 2, above or in any other form which put their reliability or credibility in question, the Principal is entitled to disqualify the Bidder(s) from the tender process.

Section 4 – Compensation for Damages

If the Principal has terminated the contract according to Section 3, or if the Principal is entitled to terminate the contract according to Section 3, the Principal shall be entitled to demand and recover from the Contractor liquidated damages of the Contract value or the amount equivalent to Performance Bank Guarantee.

Section 5 – Previous transgression

(1) The Bidder declares that no previous transgressions occurred in the last three years with any other Company in any country conforming to the anti-corruption approach or with any Public Sector Enterprise in India that could justify his exclusion from the tender process.

(2) If the Bidder makes incorrect statement on this subject, he can be disqualified from the tender process.

Section 6 – Equal treatment of all Bidders

(1) In case of Sub-contracting, the Principal Contractor shall take the responsibility of the adoption of Integrity Pact by the Sub-contractor.

(2) The Principal will enter into agreements with identical conditions as this one with all Bidders and Contractors

(3) The Principal will disqualify from the tender process all bidders who do not sign the Pact or violate its provisions.

Section 7 – Criminal charges against violating Bidder(s)

If the Principal obtains knowledge of conduct of a Bidder, Contractor or Subcontractor, or of an employee or are representative or an associate of a Bidder, Contractor or Subcontractor which constitutes corruption, or if the Principal has substantive suspicion in this regard, the Principal will inform the same to the Chief.

Section 8 – Independent External Monitor

1. The Principal appoints competent and credible Independent External Monitor for this Pact after approval by the Central Vigilance Commission. The task of the Monitor is to review independently and objectively, whether and to what extent the parties comply with the obligations under this agreement.

2. The Independent External Monitor appointed for NABARD is: Dr. Sanjay Kumar Panda, IAS (Retd.), 515, Ward no.3, Sideshwar Sahi, Cuttack City, Cuttack district, Odisha – 753008.

3. The Monitor is not subject to instructions by the representatives of the parties and performs his/her functions neutrally and independently. The Monitor would have access to all Contract documents, whenever required. It will be obligatory for him / her to treat the information and documents of the Bidders as

confidential. He / she reports to the Chairman, NABARD.

4. The Bidder(s) accepts that the Monitor has the right to access without restriction to all Project documentation of the Principal including that provided by the Contractor. The Contractor will also grant the Monitor, upon his/her request and demonstration of a valid interest, unrestricted and unconditional access to their project documentation. The same is applicable to Subcontractors.
5. The monitor is under contractual obligation to treat the information and documents of the Bidder(s)/ Contractor(s)/ Sub-Contractor(s) with confidentiality. The Monitor has also signed declarations on 'Non-disclosure of Confidential Information and of 'Absence of Conflict of Interest'. In case of any conflict of interest arising at a later date, the IEM shall inform Chairman, NABARD and recuse himself/herself from that case.
6. The Principal will provide to the Monitor sufficient information about all meetings among the parties related to the Project, provided such meetings could have an impact on the contractual relations between the Principal and the Contractor. The parties offer to the Monitor the option to participate in such meetings.
7. As soon as the Monitor notices, or believes to notice, a violation of this agreement, he/she will so inform the Management of the Principal and request the Management to discontinue or take corrective action, or to take other relevant action. The monitor can in this regard submit non-binding recommendations. Beyond this, the Monitor has no right to demand from the parties that they act in a specific manner, refrain from action or tolerate action.
8. The monitor will submit a written report to the Chairman, NABARD within 8 to 10 weeks from the date of reference or intimation to him by the Principal and, should the occasion arise, submit proposal for correcting problematic situations.
9. If the Monitor has reported to the Chairman, NABARD, a substantiated suspicion of an offence under the relevant IPC/PC Act, and the Chairman NABARD has not, within reasonable time, taken visible action to proceed against such offence or reported it to the Chief Vigilance Officer, the Monitor may also transmit this information directly to the Central Vigilance Commissioner.
10. The word 'Monitor' would include both singular and plural.

Section 9 – Pact Duration

This Pact begins when both parties have legally signed it. It shall remain in force from the date of issue of work order till completion of Defect Liability Period. Any violation of the same would entail disqualification of the bidders and exclusion from future business dealings. If any claim is made/lodged during this time, the same shall be binding and continue to be valid despite the lapse of this pact as specified above, unless it is discharge/determined by the Chairman of NABARD.

Section 10 – Other provisions

1. This agreement is subject of Indian Law, Place of performance and jurisdiction is the Head Office of the Principal, i.e. Mumbai
2. Changes and supplements as well as termination notices need to be made in writing. Side agreements have not been made.
3. The Contractor is a partnership or a consortium, this agreement must be signed by all partners or consortium members.
4. Should one or several provisions of this agreement turn out to be invalid, the remainder of this agreement remains valid
In this case, the parties will strive to come to an agreement to their original intentions.
5. Issues like Warranty/Guarantee etc. shall be outside the purview of IEMs.
6. In the event of any contradiction between the Integrity Pact and its Annexure, if any, the Clause in the Integrity Pact will prevail.

(For & On behalf of the Principal)

(For & on behalf of the Bidder)

(Office Seal)

(Office Seal)

Place

Date:

Witness 1: (Name and Address)

Appendix-5 (DEED OF INDEMNITY)

(To be executed on a non-judicial stamp paper of Rs.500/- by Successful Tenderer only)

This Deed of Indemnity is made and executed at Lucknow on this.....day of 2024 by M/Sa Company incorporated under the Companies Act, 1956, having its registered office at....., represented herein by its Authorized Signatory Shri/Smt....., Designation (herein after referred to as "Service Provider"), which expression shall, unless it be repugnant to the meaning and context thereof, include its successors, authorized agents, representatives and permitted assigns.

In favor of

NABARD for Agriculture & Rural Development, a Body Corporate established under the Act of Parliament i.e., NATIONAL BANK FOR AGRICULTURE AND RURAL DEVELOPMENT Act, 1981 having its Head Office at C-24, G - Block, Bandra Kurla Complex, Bandra (East) Mumbai- 400051 (hereinafter referred to as "NABARD") and Uttar Pradesh Regional Office at 11, Vipin Khand, Gomti Nagar, Lucknow which expression shall, unless it be repugnant to the meaning and context thereof, include its successors, authorized agents, representatives and permitted assigns.

WHEREAS the Service Provider has agreed with NABARD to successfully implement conforming to all the specifications as per the scope of work mentioned in the Tender dated (hereinafter referred to as "Tender" No.) which expression shall include all attachments and annexures thereto as well as all amendments, modifications and alteration and the Terms and Conditions agreed as per Agreement dated (hereinafter referred to as "Agreement").

AND WHEREAS pursuant to the Agreement, the Service Provider is required to execute a Deed of Indemnity in favour of NABARD to indemnify it against any acts, omissions, losses, charges, claims etc. and which the Service Provider has agreed to do.

NOW THIS DEED WITNESSETH AS UNDER:

1. The Service Provider hereby executes and furnishes to NABARD this Deed of Indemnity, which is an unlimited, irrevocable and continuing indemnity, and shall remain in full force and effect.

2. The Service Provider hereby undertakes to indemnify NABARD as per the Terms and Conditions of the Agreement which are as follows:

(a) The Service Provider shall execute and furnish to NABARD a Deed of Indemnity, indemnifying NABARD from and against any costs, loss, damages, expense, claims whether on account of patents, trademarks, copyrights issues or otherwise including those from third parties or liabilities of any kind howsoever suffered, arising or incurred inter alia during and after the Agreement period arising out of:

- (i) Any negligence or wrongful act or omission by the Service Provider, the Service Provider's team or any third party in connection with or incidental to this Agreement; or
- (ii) Any breach of any of the terms of the Bid as agreed, the Tender and the Agreement by the Service Provider, the Service Provider's Team or any third party.
- (iii) The indemnity shall be to the extent of 100% in favour of NABARD.
- (iv) Notwithstanding the above, Service Provider shall have no obligations with respect to any indemnity claims to the extent that the indemnity claim arises or results from:
- (v) Service Provider's compliance with NABARD's specific technical designs or instructions;
- (vi) Inclusion in a Service of any content or other materials provided by NABARD;
- (vii) Modification of a Service after delivery by Service Provider to NABARD if such modification was not made by or on behalf of the Service Provider, provided the modification is not in accordance with any applicable specifications or documentation provided by or on behalf of the Service Provider;

(viii) Operation or use of some or all of the Service in combination with products, information, specification, instructions, data, materials not provided by or on behalf of the Service Provider, provided the modification is not in accordance with any applicable specifications or documentation provided by or on behalf of the Service Provider; or

(ix) Use of the Services for any purposes for which the same has not been designed or developed or other than in accordance with any applicable specifications or documentation provided by or on behalf of the Service Provider; or

(x) NABARD's failure to use any modification of the Service furnished under this Agreement and communicated in writing in accordance with the requirements of clause 'Notices' including, but not limited to, corrections, fixes, or enhancements made available by the Service Provider.

(xi) Service Provider will defend, indemnify and hold harmless NABARD from and against any third party suit, proceedings damages, judgments, cost and expenses (including reasonable attorney fees) relating to any infringement claim by a third party to the extent based on any NABARD materials provided to Service Provider by or on behalf of NABARD or the access and use by Service Provider of any NABARD provided software or material.

(xii) Provided that the provision by NABARD and the access and use by the Service Provider is in connection with Service Provider's performance of services hereunder and without breaching the terms of this Agreement.

(xiii) The Service Provider shall procure all the necessary permissions, approvals and licenses for use of various software and any copyrighted process/product free from all claims, titles, interests and liens thereon and shall keep NABARD indemnified in relation thereto.

(xiv) The Service Provider owns, has license to use or otherwise has the right to use, free of any pending or threatened liens or other security or other interests all its Intellectual Property Rights, which are required or desirable for performance of its services under this Agreement and regarding the same the Service Provider does not, so far as the Service Provider is aware, in carrying on its business and operations, infringe any Intellectual Property Rights of any person. So far as the Service Provider is aware, none of the Intellectual Property Rights, owned or enjoyed by the Service Provider or which the Service Provider is licensed to use, which are material in the context of Service Provider's business and operations for the performance of this Agreement are being infringed nor, so far as the Service Provider is aware, is there any infringement or threatened infringement of those Intellectual Property Rights licensed or provided to the Service Provider by any person. All Intellectual Property Rights (owned by the Service Provider or which the Service Provider is licensed to use) required by the Service Provider for the performance of this Agreement are valid and subsisting. All actions (including registration, payment of all registration and renewal fees) required to maintain the same in full force and effect have been taken thereon and shall keep NABARD indemnified in relation thereto.

(xv) During the tenure of the Agreement, nothing shall be done by the Service Provider in contravention of any law, Acts, or rules and regulations there under, or any amendments thereof and shall keep NABARD, indemnified in this regard.

3. The Service Provider hereby undertakes that it shall forthwith on demand and without demur pay to NABARD such sum or sums that is 100% in favour of NABARD as may be claimed by NABARD as losses, damages, costs, charges or expenses by reason of such above mentioned default/ defaults on the Service Provider's part.

4. Notwithstanding anything to the contrary in these presents or in the Agreement, NABARD's decision as to whether the Service Provider has made any default/ defaults or the amounts to which NABARD is entitled by reason thereof will be binding on the Service Provider for the purpose of this Indemnity and the Service Provider shall not be entitled to ask NABARD to establish its claims under this Indemnity but will pay the same, on demand, without any objection, provided always, the mutual rights under the Agreement shall not in any way be prejudiced by reason of such demand by NABARD and payment by the Service Provider under this Indemnity and the claims under the Agreement which shall be settled in accordance with the Agreement without prejudice to NABARD's rights to demand immediately under this Indemnity and the Service Provider's liability to pay the same.

5. This Deed of Indemnity shall be valid for the Agreement Period and can be renewed thereof whenever a

claim as per this Deed of Indemnity arises.

6. NABARD will have the fullest liberty from time to time to enforce or forbear to enforce any of the terms & conditions of the Agreement and the Service Provider shall not be released from its liability under this Deed of Indemnity by the exercise of NABARD's liberty with reference to the matters aforesaid or by reason of any time being given to the Service Provider or any forbearance, act or omission on NABARD's part or any indulgence by NABARD to the Service Provider or by any variations or modifications of the Agreement or any other act, matter or thing whatsoever on NABARD's part.

7. This Indemnity and the powers and provisions herein contained are in addition to and not by way of limitation or substitution for any other guarantee ,indemnities hereto before, given to NABARD by the Service Provider and this Indemnity does not revoke or limit such indemnities or guarantee.

IN WITNESS WHEREOF, the Service Provider has caused this Deed of Indemnity to be duly executed as of the day, month and year first written above.

Signed and delivered by: *Name of M/S SERVICE PROVIDER*

Place:

Date:

In the presence of

1.

2.

Appendix-6

(RECIPROCAL NON-DISCLOSURE AGREEMENT)

(To be executed on a non-judicial stamp paper of Rs. 200/- by Successful Tenderer only)

This Agreement (“Agreement”) is entered into on this day of2022 between:

NABARD for Agriculture & Rural Development, a Body Corporate established under the Act of Parliament i.e., National Bank For Agriculture And Rural Development Act, 1981 HAVING its Head Office at C-24, G - Block, Bandra Kurla Complex, Bandra (East) Mumbai- 400051 and Regional office at 11, Vipin Khand, Gomti Nagar, Uttar Pradesh, represented herein by its Authorised Signatory, Shri/Smt....., Deputy General Manager, Department of Premises, Security and Procurement, NABARD UPRO Lucknow (hereinafter referred to as "NABARD"), which expression shall, unless it be repugnant to the meaning and context thereof, include its successors, authorized agents, representatives and permitted assigns of the one part.

AND

M/s....., having its registered office at represented herein by its Authorised Signatory Shri/Smt., Designation..... (hereinafter referred to as "Service Provider"), which expression shall, unless it be repugnant to the meaning and context thereof, include its successors, authorized agents, representatives and permitted assigns of the other part.

Hereafter referred to individually as a “**Party**” and collectively as the “**Parties**”. For purposes of this Agreement, the party receiving Confidential Information (as defined herein below), shall be referred to as the “**Receiving Party**” and the party providing the Confidential Information shall be referred to as the “**Disclosing Party**”.

WHEREAS is *inter alia* engaged in the business of provision of various information technology services, consultancy and outsourcing services worldwide.

AND WHEREAS, NABARD is engaged in the activities as provided under the NABARD Act, 1981

AND WHEREAS and NABARD are in the process of Terrace Water Proofing work as described in Scope of work mentioned in the Tender document Ref No..... dated (“Purpose”).

To facilitate such items of work, certain Confidential Information (as defined below) will be required to be shared between the Parties.

AND WHEREAS, The parties wish to protect any such Confidential Information in accordance with the terms and conditions of this agreement (the "Agreement").

NOW, THEREFORE, in consideration of receipt of Confidential Information it is agreed as follows:

A. Definition of “Confidential Information”

“**Confidential Information**” means any information disclosed to, received by, otherwise accessed by or coming to the knowledge of any Party to this Agreement that:

- i. by its character or nature or by the circumstances in which it is disclosed/received/ assessed/or

it came to knowledge, such that a reasonable person under like circumstances would treat it as confidential; or

ii. Is designated by the disclosing party as confidential or identified in terms connoting its confidentiality; or

iii. The disclosing party considers confidential and includes but is not limited to, the following types of information and other information of a similar nature (whether or not reduced to writing): discoveries; concepts; software in various stages of development; designs; drawings; specifications; techniques; models; data; source code; object code; documentation; processes; procedures; know-how; marketing techniques and materials; marketing and development plans; customer names and other information related to customers, price lists, pricing policies and financial information. Confidential Information also includes information disclosed to the Receiving Party by third parties on behalf of the Disclosing Party.

B. Information not categorized as “Confidential Information”

The obligation imposed, under this Agreement, on Receiving Party shall not apply to information which:

(a) Receiving Party can demonstrate by prior existing records, was within Receiving Party's legitimate possession prior to the time of disclosure;

(b) was within the public domain prior to disclosure, or comes into the public domain through no wrongful act, fault, negligence or breach of this Agreement on the part of the Receiving Party;

(c) is independently developed by the Receiving Party without reference to or reliance upon Confidential Information of the Disclosing Party;

(d) Is or becomes lawfully available to Receiving Party on a non-confidential basis from an independent source who is free to divulge such information.

C. Restriction on Disclosure

Except as otherwise expressly permitted under this Agreement, Receiving party shall not:

(a) Disclose, duplicate, copy, transmit or otherwise disseminate in any manner whatsoever any Confidential Information of the Disclosing Party;

(b) Use the Confidential Information of the Disclosing Party (i) for Receiving Party's own benefit or that of any third party, (ii) to the Disclosing Party's detriment, or (iii) for any purpose other than for achieving the Purpose;

(c) Commercially exploit any Confidential Information of the Disclosing Party;

(d) Acquire any right in, or assert any lien against, the Confidential Information of the Disclosing Party; or

(e) Refuse for any reason to promptly return all Confidential Information of the Disclosing Party if requested to do so.

D. Permitted Disclosures

Receiving party is permitted to:

(a) Disclose relevant aspects of the Disclosing Party's Confidential Information to the Receiving Party's directors, officers, employees, consultants, attorneys and auditors solely to the extent

necessary for achieving the Purpose; provided, that

(i) Before disclosing any Confidential Information of the Disclosing Party, all persons or entities receiving Confidential Information shall be bound by obligations of confidentiality towards the Receiving Party consistent with the terms of this Agreement.

(ii) The Receiving Party shall do everything reasonably possible to preserve the confidentiality of the Confidential Information including execution of a confidentiality agreement with the persons or entities receiving Confidential Information to the satisfaction of the Disclosing Party.

(iii) All such Confidential Information shall be labelled as confidential.

(b) Disclose relevant aspects of the Disclosing Party's Confidential Information if legally compelled or required to disclose any Confidential Information of the Disclosing Party in connection with any legal or regulatory proceedings. In such case, the Receiving Party will immediately notify the Disclosing Party so as to allow the Disclosing Party a reasonable opportunity to seek appropriate protective measures or other remedies prior to disclosure or waive compliance with the terms of this Agreement.

(c) Disclose relevant aspects of the Disclosing Party's Confidential Information with the prior written consent of the Disclosing Party.

E. Effects of Unauthorized Disclosure

(a) The Receiving Party will be liable for the acts and omissions of, and any unauthorized disclosure or use of Confidential Information by, any person or entity that received Confidential Information from or through the Receiving Party.

(b) Each Party acknowledges and agrees that the misappropriation or misuse of Confidential Information of the other Party will result in irreparable and continuing damage to the other Party for which there may be no adequate remedy at law, and in the event of such a breach, the other Party shall be entitled to legal as well as equitable relief, as appropriate, including but not limited to an injunction, in addition to any monetary relief.

(c) The Receiving Party will promptly report to the Disclosing Party any disclosures of Confidential Information otherwise than as permitted by this Agreement and any breaches in security that may affect the Disclosing Party or its Confidential Information of which it is aware and will specify the corrective action to be taken.

F. Return of documents

Upon written demand by the Disclosing Party, the Receiving Party shall:

a. Return to the Disclosing Party all Confidential Information supplied which the Receiving Party has in his possession or under his control;

b. Destroy or have destroyed all copies received or made of the Confidential Information; and

c. Promptly thereafter provide a certificate signed by an officer of the Receiving Party certifying compliance with the obligations point (a) and (b) above.

G. Term

This Agreement shall commence from the date of issue of work order unless earlier terminated in writing by both Parties. The obligations under this Agreement shall survive and continue for the period for which the work has to be completed (45 days) shall be executed.

H. Governing Law and Jurisdiction

This Agreement shall be governed by and construed in accordance with the laws of India. Any and all disputes arising out of or in connection with this Agreement shall be settled by the courts in Lucknow, India

I. Miscellaneous

(a) No failure or delay by the Disclosing party in exercising or enforcing any right, remedy or power hereunder shall operate as a waiver thereof, nor shall any single or partial exercise or enforcement of any right, remedy or power preclude any further exercise or enforcement thereof or the exercise or enforcement of any other right, remedy or power.

(b) This Agreement shall not be assignable or transferable by either Party without the written consent of the other Party.

(c) This Agreement supersedes all prior discussions and writings with respect to the subject matter hereof, and constitutes the entire agreement between the Parties with respect to the subject hereof. No waiver or modification of this Agreement will be binding upon either Party unless made in writing and signed by a duly authorized representative of each Party.

(d) In the event that any of the provisions of this Agreement shall be held by a Court or other tribunal of competent jurisdiction to be unenforceable, the remaining portions hereof shall remain in full force and effect.

IN WITNESS WHEREOF this Agreement has been executed by the duly authorized representative of each Party on the day and year above written.

By:
Name:
Title:

NABARD

By:
Title:
Date:

Witnesses:

- 1.
- 2.

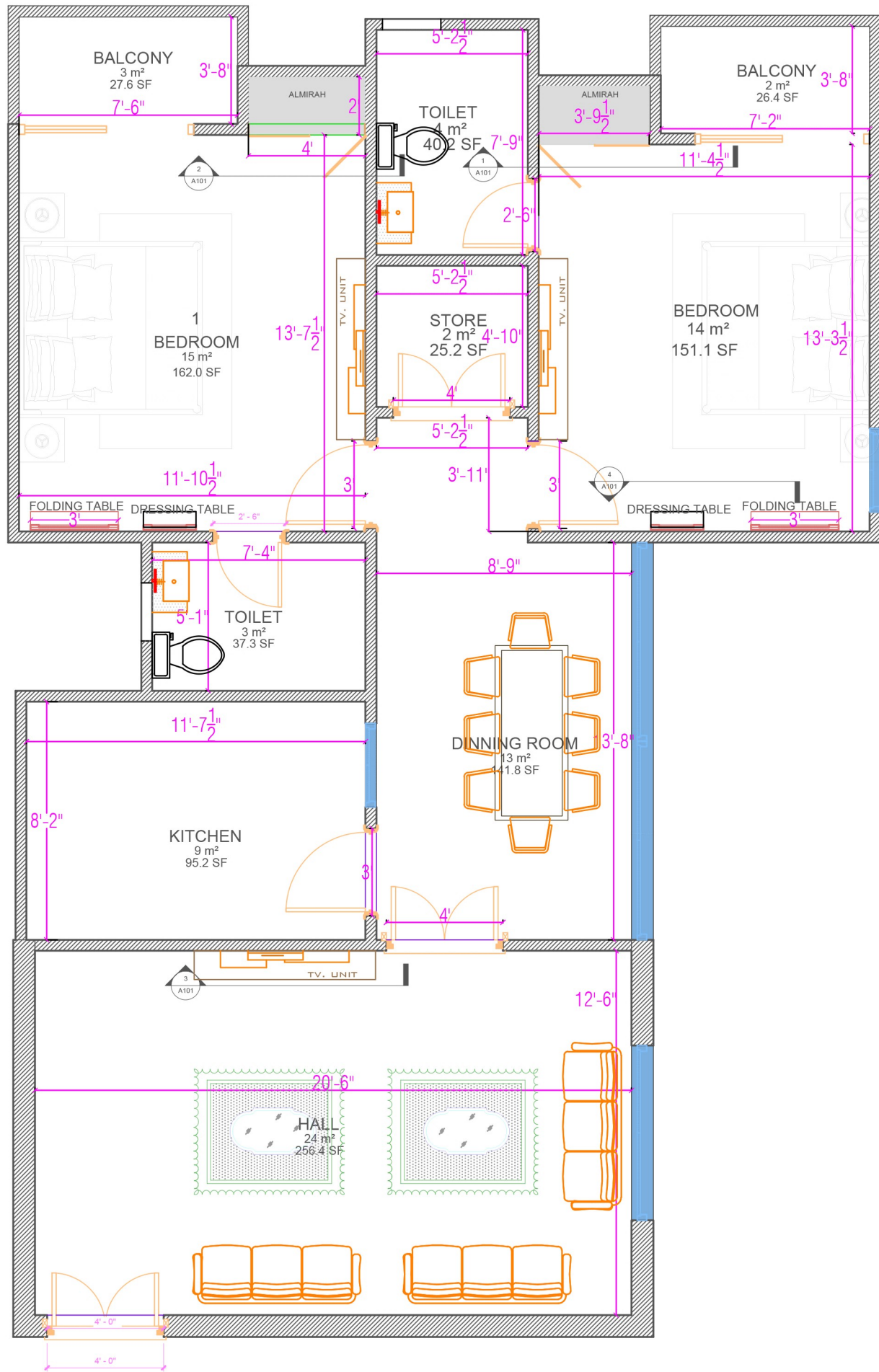

FLOOR PLAN

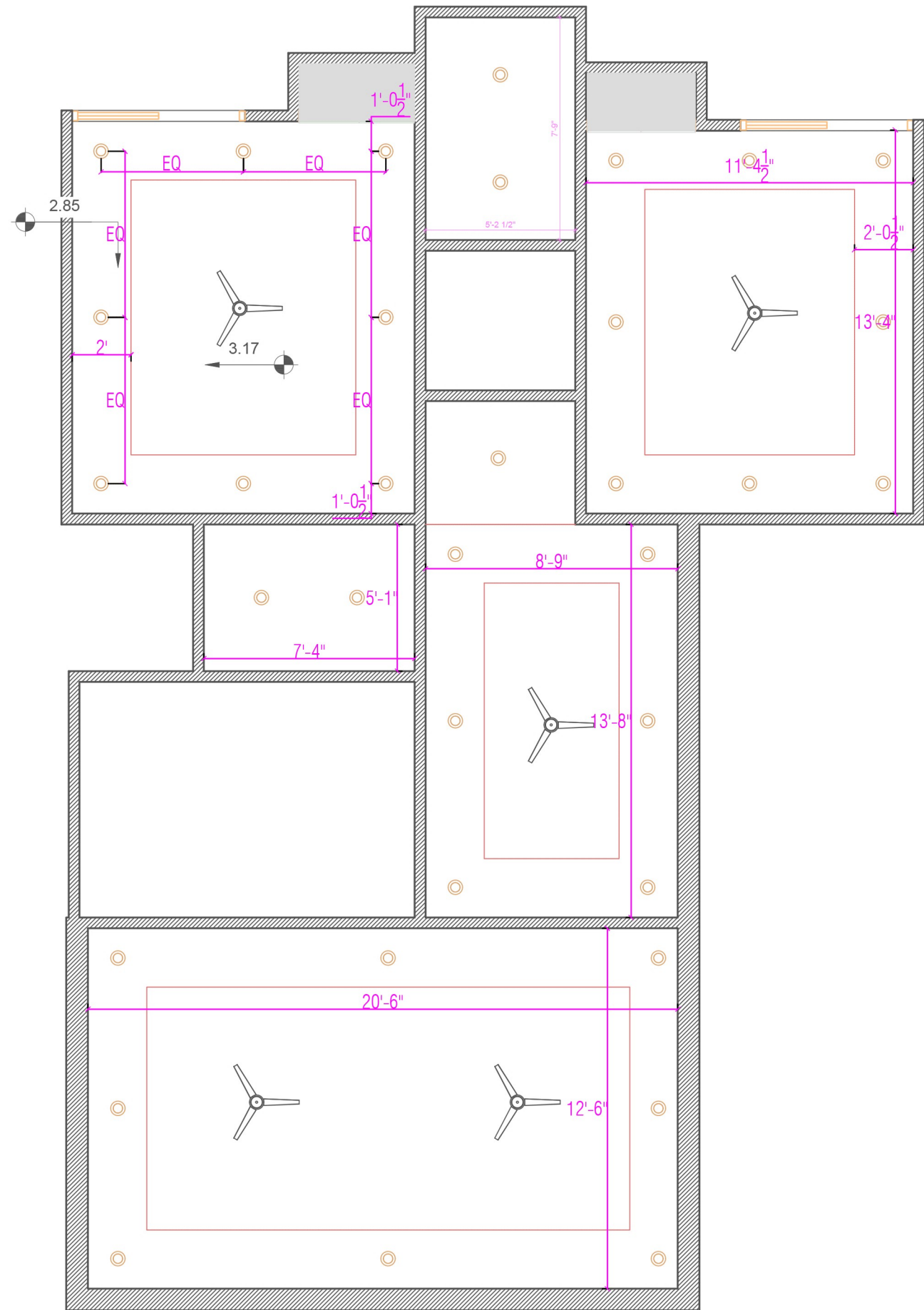

FALSE CEILING PLAN

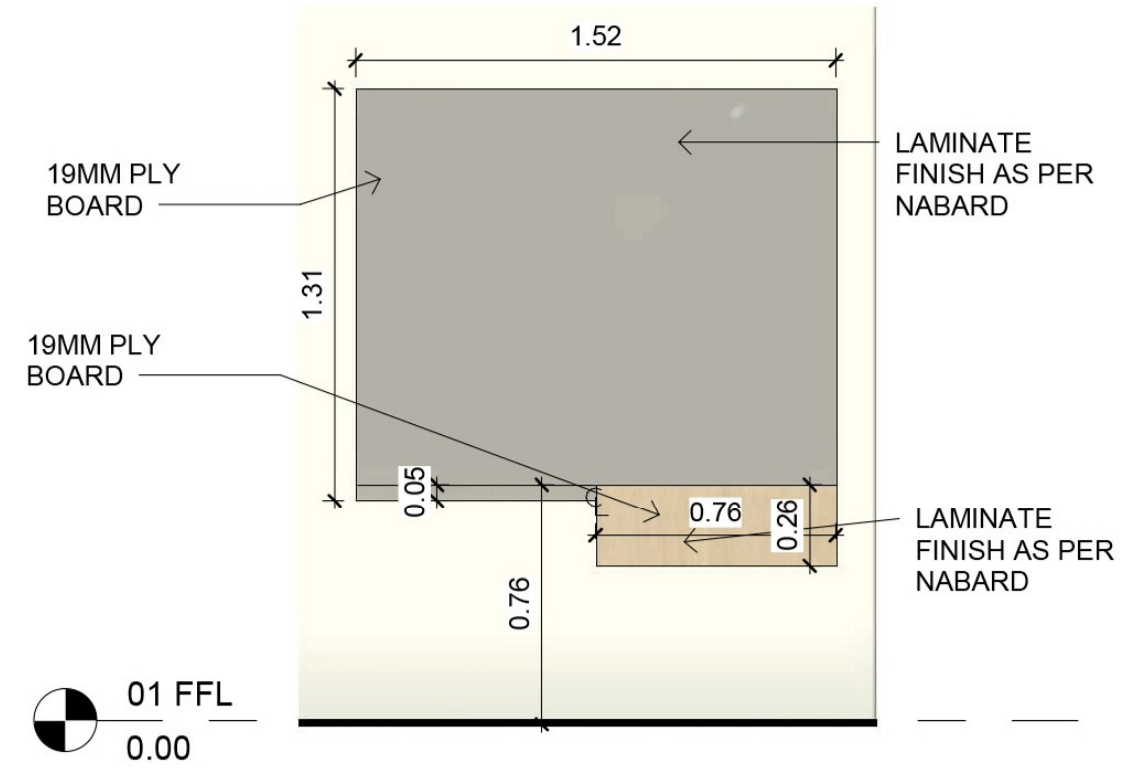
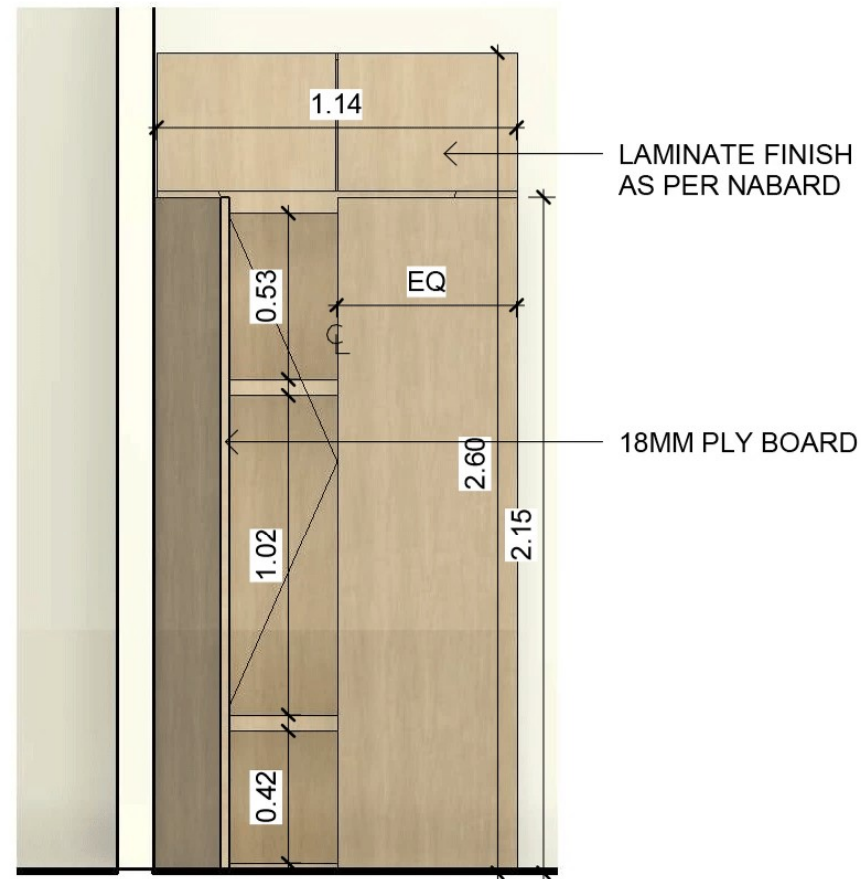
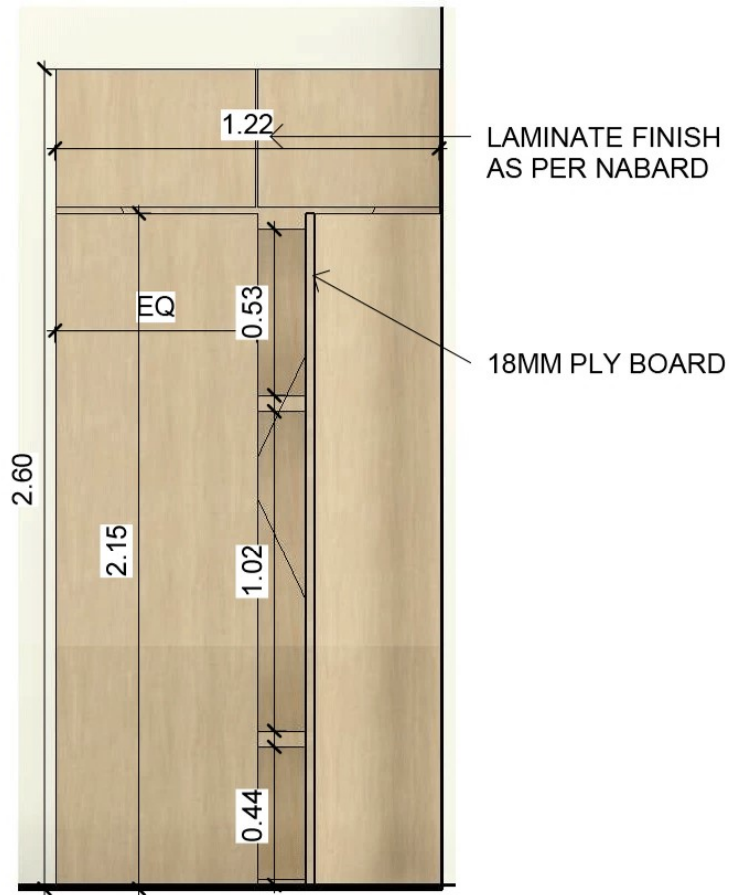

3 TV UNIT
1 : 25

2 WARDROBE BEDROOM 1
1 : 25

1 WARDROBE BEDROOM 2
1 : 25

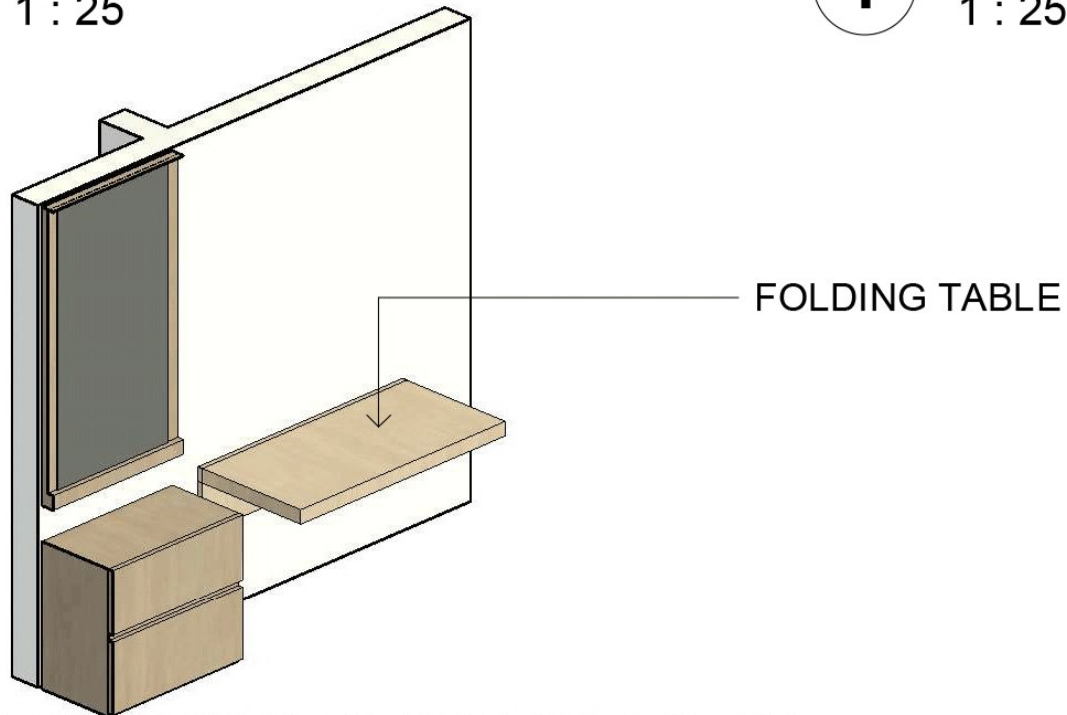

6 FOLDING DESK 3D VIEW

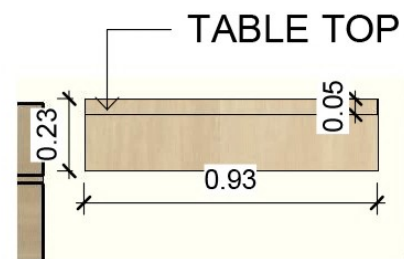

5 FOLDING DESK
1 : 25

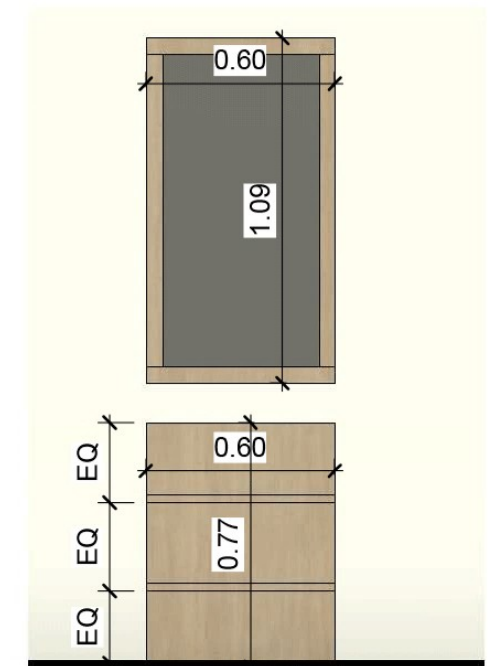

4 DRESSING TABLE WITH MIRROR
1 : 25

ESTIMATE FOR RENOVATION OF VOF AT LA-PLACE , HAZRATGANJ ,LUCKNOW						
SR.NO.	DSR-2021	Description of Item	UNIT	QTY.	Rates	Amount
(i) FURNISHING:-						
1		FALSE CEILING				
1.1	12.45	Providing and fixing false ceiling at all height including providing and fixing of frame work made of special sections, power pressed from M.S. sheets and galvanized with zinc coating of 120 gms/sqm (both side inclusive) as per IS : 277 and consisting of angle cleats of size 25 mm wide x 1.6 mm thick with flanges of 27 mm and 37mm, at 1200 mm centre to centre, one flange fixed to the ceiling with dash fastener 12.5 mm dia x 50mm long with 6mm dia bolts, other flange of cleat fixed to the angle hangers of 25x10x0.50 mm of required length with nuts & bolts of required size and other end of angle hanger fixed with intermediate G.I. channels 45x15x0.9 mm running at the spacing of 1200 mm centre to centre, to which the ceiling section 0.5 mm thick bottom wedge of 80 mm with tapered flanges of 26 mm each having lips of 10.5 mm, at 450 mm centre to centre, shall be fixed in a direction perpendicular to G.I. intermediate channel with connecting clips made out of 2.64 mm dia x 230 mm long G.I. wire at every junction, including fixing perimeter channels 0.5 mm thick 27 mm high having flanges of 20 mm and 30 mm long, the perimeter of ceiling fixed to wall/partition with the help of rawl plugs at 450 mm centre, with 25mm long dry wall screws @ 230 mm interval, including fixing of gypsum board to ceiling section and perimeter channel with the help of dry wall screws of size 3.5 x 25 mm at 230 mm c/c, including jointing and finishing to a flush finish of tapered and square edges of the board with recommended jointing compound , jointing tapes , finishing with jointing compound in 3 layers covering upto 150 mm on both sides of joint and two coats of primer suitable for board, all as per manufacturer's specification and also including the cost of making openings for light fittings, grills, diffusers, cutouts made with frame of perimeter channels suitably fixed, all complete as per drawings, specification and direction of the Engineer in Charge/Authorised NABARD Official but excluding the cost of painting with :				
	12.45.4	Fully Perforated Gypsum Plaster Board of size 1200 x 2400x12.5 mm having approx. 15 % perforated area with perforation size and pattern as approved by the Engineer in Charge/Authorised NABARD Official and as per manufacturer's specification, with all 4 side tapered and backed by acoustical tissue with NRC value not less than 0.60				
1.1.1		BEDROOM 1	sqm	15.02		
1.1.2		BEDROOM 2	sqm	14.04		
1.1.3		DINNING ROOM	sqm	11.11		
1.1.4		LOBBY ROOM	sqm	23.83		
1.1.5		FOYER AREA	sqm	2.05		
1.1.6	12.52.3	12.5 mm thick square edge PVC Laminated Gypsum Tile of size 595x595 mm , made of Gypsum plasterboard, manufactured from natural gypsum as per IS 2095 part I and laminated with white 0.16mm thick fire retardant PVC film on the face side and 12micron metalized polyester on the back side with all edges sealed with the face side PVC film which goes around and wraps the edges and is bonded to the edges and the back side metalized polyester film so as to make the tile a completely sealed unit.				
1.1.6.1		TOILET 1	sqm	3.72		
1.1.6.2		TOILET 2	sqm	3.45		
TOTAL (SAY A)						0.00

2		ALMIRAH				
2.1		Providing, Making & Placing Wardrobe all made up of 19mm thick marine ply as per IS 710 with back boxing in 8mm thick plywood resting on 100mm wide laminated skirting, wardrobe from front divided into two equal division of 1000mm each with following description with 18mm thick plywood. NOTE: Providing and fixing 19mm thick both side balancing lamination factory pressed BWP grade marine ply as per IS 710 of approved brand boxes,shelves,racks,almirah,cupboard and drawer etc. including necessary nails,screws etc. complete as per direction of Engineer in Charge/Authorised NABARD Official.				
2.1.2	Market Rate	Size : 1.14m(w) x 0.6m(d) x 2.60m(ht.) (BEDROOM - 2)	sqm	1		
2.1.3	Market Rate	Size : 1.12m(w) x 0.6m(d) x 2.60m(ht.) (BEDROOM - 1)	sqm	1		
TOTAL (SAY B)						0.00
3		TV UNIT				
3.1	Market Rate	Providing, Making & Placing of TV unit of size 1.52 mX 1.31 m made out of 19mm thick commercial board cladded with 6.00mm ply over it for making 10mm wide grooves. Grooves will be cladded with 10mm thick SS profile. Laminate of 1.00 mm thickness of approved shade along with the cove from the sides will be placed over 6mm laminate. The Unit also includes a counter of size 0.76m X 0.30m x 0.26m with drawers made out of 19mm commercial board as per the design approved by the NABARD.				
			Nos.	3		
TOTAL (SAY C)						0.00
4		DRESSING TABLE WITH MIRROR				
4.1.1	Market Rate	Providing, Making & Placing of DRESSING TABLE WITH MIRROR . Dressing table size : 0.6m(length) x 0.7m (height) x 0.25m(depth) with 3 Drawer with handle / profile equally divided into 3 parts made out of 19mm thick commerical board cladded with Mica/Laminate approved by the NABARD. with 0.9m x 1.09m size Frame for Mirror with 0.05m frame made of 19mm commerical board including Satin gobin Glass inside frame.				
			Nos.	2		
4.1.2	Market Rate	Providing and Fixing of FOLDING DESK - WALL MOUNTED (Supported by Good Quality Non Rust Chains) : foldable 0.93m(length) x0.43m (depth) NOTE: Providing and fixing 19mm thick both side balancing lamination factory pressed BWP grade marine ply as per IS 710 of approved brand boxes,shelves,racks,almirah,cupboard and drawer etc. including necessary nails,screws etc. complete as per direction of Engineer in Charge/Authorised NABARD Official.				
			Nos.	2		
TOTAL (SAY D)						0.00
5		DOORS				
5.1		Providing and fixing Steam Beach Wooden Door Frame in position , complete in all respect including two coats of melamine polish. Fixing chowkhats in existing opening including embedding chowkhats in floors or walls cutting masonry for holdfasts, embedding hold fasts in cement concrete blocks of size 15 x 10 x 10 cm with cement concrete 1:3:6 (1 cement : 3 coarse sand : 6 graded stone aggregate 20 mm nominal size), painting two coats of approved wood preservative to sides of chowkhats and making good the damages to walls and floors as required complete, including disposal of rubbish to the dumping ground, all complete as per direction of Engineer in Charge/Authorised NABARD Official. (Note : Door Chowkhats fixing charge per Door Rs.1505/- included)				
5.1.2		Steam Beach Wooden Door Frame Size : 2.1m(height) x 0.9m (width)	Nos.	3		

5.1.3		Steam Beach Wooden Door Frame 2.1m(height) x 1.2m (width)	Size :	Nos.	2		
		Flush Door Shutters					
5.2	9.20	Providing and fixing ISI marked flush door shutters conforming to IS : 2202 (Part I) decorative type, core of block board construction with frame of 1st class hard wood and well matched teak 3 ply veneering with vertical grains or cross bands and face veneers on both faces of shutters. (NOTE: 35 mm thick including ISI marked Stainless Steel butt hinges with necessary screws RS.3086.1/- sqmt, DOOR LOCK & FITTINGS / SCREWS / DOOR STOPPER / LATCHES FOR ALL DOORS)					
5.3		Door Shutter Size : 2.1m(height) x 0.9m (width)		Nos.	3		
5.4		Door Shutter Size : 2.1m(height) x 1.2m (width)		Nos.	2		
	8736	Bathroom PVC DOOR: 35 mm thick factory made solid panel PVC door shutter of single piece extruded profile decorative finished (wood grain finished) Note Size: Door With Frame Size : (2.1m x 0.76m)		Nos.	2		
TOTAL (SAY E)							0.00
6		UPVC DOOR WINDOWS					
6.1	9.147D	Providing and fixing factory made uPVC white colour sliding glazed window upto 1.50 m in height dimension comprising of uPVC multi-chambered frame with in-built roller track and sash extruded profiles duly reinforced with 1.60 ± 0.2 mm thick galvanized mild steel section made from roll forming process of required length (shape & size according to uPVC profile), appropriate dimension of uPVC extruded glazing beads and uPVC extruded interlocks, EPDM gasket, wool pile, zinc alloy (white powder coated) touch locks with hook, zinc alloy body with single nylon rollers (weight bearing capacity to be 40 kg), G.I fasteners 100 x 8 mm size for fixing frame to finished wall and necessary stainless steel screws etc. Profile of frame & sash shall be mitred cut and fusion welded at all corners, including drilling of holes for fixing hardware's and drainage of water etc. After fixing frame the gap between frame and adjacent finished wall shall be filled with weather proof silicon sealant over backer rod of required size and of approved quality, all complete as per approved drawing & direction of Engineer in Charge/Authorised NABARD Official. (Single / double glass panes, wire mesh and silicon sealant shall be paid separately). Variation in profile dimension on higher side shall be accepted but no extra payment on this account shall be made.					
6.1.1	9.147D.2	Three track three panels sliding window with fly proof SS wire mesh (Two nos. glazed & one no. wire mesh panels) made of (small series) frame 92 x 44 mm & sash 32 x 60 mm both having wall thickness of 1.9 ± 0.2 mm and single glazing bead of appropriate dimension (Area of window upto 1.75 sqm).		sqmt	9.41		
6.1.2	9.147F.4	Three track three panels sliding door with fly proof S.S wire mesh (Two nos. glazed & one no. wire mesh panels) made of (big series) frame 116 x 45 mm & sash 46 x 82 mm both having wall thickness of 2.3 ± 0.2 mm and single glazing bead / double glazing bead of appropriate dimension. (Area of door above 2.00 sqm upto 5.00 sqm)		sqmt	9.8		
TOTAL (SAY F)							0.00
7		PAINTING					
7.1	13.26	Providing and applying plaster of paris putty of 2 mm thickness over plastered surface to prepare the surface even and smooth complete.		sqm	449.56		
7.2	13.43	Applying one coat of water thinnable cement primer of approved brand and manufacture on wall surface :					

7.3	13.43.1	Water thinnable cement primer	sqmt	449.56		
7.4	13.83	Wall painting with premium acrylic emulsion paint of interior grade, having VOC (Volatile Organic Compound) content less than 50 grams/ litre of approved brand and manufacture, including applying additional coats wherever required to achieve even shade and colour.				
7.5	13.83.2	Two coats	sqmt	449.56		
TOTAL (SAY G)						0.00
FLOORING						
8						
8.1	11.41A	Providing and laying Vitrified tiles in floor in different sizes (thickness : 12mm) with water absorption less than 0.08% and conforming to IS:15622, of approved brand & manufacturer, in all colours and shade, laid on 20 mm thick cement mortar 1:4 (1 cement: 4 coarse sand) jointing with grey cement slurry @3.3 kg/sqm including grouting the joints with white cement and matching pigments etc. The tiles must be cut with the zero chipping diamond cutter only . Laying of tiles will be done with the notch trowel, plier, wedge, clips of required thickness, leveling system and rubber mallet for placing the tiles gently and easily.				
8.2	11.41A.2	Glazed vitrified floor tiles polished finish of size				
8.3	11.41A.2.2	Size of Tile 600 x 1200 mm (thickness : 12mm)	SQMT	73.36		
8.4	11.41A.2.2	Tile work in skirting: Size of Tile 600 x 1200 mm (thickness : 12mm)	SQMT	25.65		
8.6	11.49	Providing and laying Vitrified tiles in floor with different sizes (thickness to be specified by the manufacturer), with water absorption less than 0.08% and conforming to IS:15622, of approved brand & manufacturer, in all colours and shade, laid with cement based high polymer modified quick set tile adhesive (water based) conforming to IS : 15477, in average 6 mm thickness, including grouting of joints				
8.7	11.49.1	BATHROOM FLOOR & WALL TILE: Size of Tile 500x500 mm	SQMT	43.6		
TOTAL (SAY H)						0.00
(ii) PLUMBING AND SANITARY FIXTURES:-						
1		Providing and fixing vitreous European type WC pan [CARLTON Wall Hung - Cat. No.: S1044147 from CERA] of Colour: White. With 'P' trap including 10 liters low level concealed cistern [CATRINA - Cat. No. B1110103 Twin flush of CERA in wall with 'M' Knob press panel of chrome shinny colour including brass working parts and brass ball valve with PVC floating ball ceramic siphon with all fittings such as C.P supply connection 15mm diameter angle type brass C.P. stopcock with brass C.P wall cap,32mm diameter long bend C.P. flush pipe with fittings including cutting and making good the walls and floor including close seat cover [Cat No. : S1043147 of CERA], Colour: White, complete in all respect Note: All CP fittings used should be of Jaquar]	No.s	2		
2		Providing and fixing white color wash basin [CARMONA Table top Wash basin - Cat No. : S2020162 of make CERA] with manifold bracket, 32 mm diameter outlet, with 32 mm diameter C.P. bottle trap with brass C.P. wall cap and extension pieces, 15 mm diameter C.P. brass angle stop cock with 10mm diameter C.P. brass connection pipe etc. CP brass chain, CP wall flange, rubber adopter for waste connection complete, including cutting and making good the walls wherever required 3 coats of paints to brackets complete fixing etc. [Note: All CP fittings used should be of Jaquar]	No.s	2		
3		Providing and fixing 15mm nominal diameter CP concealed stop cock with wall flange of Jaquar, Cat No. : FUS - 29083K.	No.s	4		

4		Providing and fixing position superior quality mirror 6mm thick glass of Modi / Ashai/Saint Gobain fixed with 25mm diameter head less SS stud maintaining 30 mm gap with tiled wall of following sizes:				
5		1200mm (L) x 1200mm (Ht.)	No.s	2		
6		Providing and fixing in position overhead shower [Rectangular] of make Jaquar, Cat No. : OHS- CHR-35497	No.s	2		
7		Providing and fixing in position bath and shower wall mixer of make Jaquar, Cat No. : FUS- 29273UPR	No.s	2		
8		Providing and fixing concealed stop cock of make Jaquar, Cat No. : FUS-CHR-29441K	No.s	8		
9		Single Lever Basin Mixer Wall Mounted Consisting of Operating Lever, Cartridge Sleeve, Wall Flange, Nipple & Spout along with flexible hose pipe complete in all respect Jaquar, Cat No.DRC-CHR-37233NK	No.s	2		
10		Providing and Fixing double robe hook.	No.s	4		
11		Soap Dish Holder - Chrome (Jaquar : CODE: ACN-CHR-1131N)	No.s	2		
12		Toilet paper holder - (Jaquar: CODE: AHS- CHR-1553)	No.s	2		
13		P/P Solid pedal bin in stainless steel [Grade : 202] with rubber rim at bottom of overall diameter 175mm & ht. 250mm with black PVC bucket of make: Ozone	No.s	6		
14		Towel Rack:Jaquar CODE: AHS-CHR-1581	No.s	2		
15		Towel Ring Round with Round Flange - Chrome Jaquar : CODE: ACN-CHR-1121BN	No.s	2		
16		P & F of Jet shower in WC pan with 15mm diameter SS connection complete. Jaquar: CODE: ALD-CHR-577	No.s	2		
17	MARKET RATE	Anti-Termite treatment [Post- construction with 5 years of warranty: certificate from company required] [Measurement: By floor area].	SQMT	162		
TOTAL (SAY I)						0.00
18	SOIL, WASTE & RAINWATER PIPE & FITTINGS					
19		Providing and fixing PVC PIPE [6 kg/cm ²] for soil, waste and vent pipes with fittings such as bends, elbow, sockets, union, plain shoes all fittings etc., cutting and making good the holes or chase in walls or floors and making complete [pipes and fittings shall be of approved make. 75mm Diameter	Mts	5		
20		Providing and fixing PVC waste pipe including painting with two coats of bitumastic paint, wrapping with applying a final coat of bitumastic paint [for pipes in chase or under floor] conforming to IS: 1239 [Medium Class] complete with GI fittings and clamps including cutting and making good the walls for wash basins and kitchen sinks etc. disposal with waste connection etc. complete.				
21		32 mm N.B.	Mts	6		
22		40 mm N.B.	Mts	4		
23		50 mm N.B.	Mts	4		
24		Providing and fixing Chilly stainless steel floor grating of Pisto Super Series [PS 005]	No.s	8		
25		WATER SUPPLY				
26		Providing and fixing CPVC [medium duty] complete with all Fitting such as elbow sockets, union, nipples etc. complete. Brand Supreme				
26.1		15 mm diameter	rmt	12		
26.2		20 mm diameter	rmt	8		

26.3		25 mm diameter	rmt	6		
TOTAL (SAY J)						0.00
27		LIGHTING FIXTURES				
28		Providing and installation of Ceiling Light LED Down Product Code: 5w Round Astra Max Plus LED DL (WW) Lamp Used: LED Wattage (W): 5W, Voltage (V): 220 to 240 Size: 110mm Diameter, Make: PHILIPS	NO.S	32		
29		Providing and installation of LED Strip 5m	NO.S	7		
Total (SAY K)						0.00
(iii) CIVIL WORKS:-						
1	14.88	Providing and laying in situ seven course water proofing treatment with APP (Atactic Polypropylene) modified Polymeric memberaneover roof consisting of first coat of bitumen primer @ 0.40 litre per sqm, 2nd, 4th & 6th courses of bonding material @ 1.20 kg/sqm, which shall consist of blown type bitumen of grade 85/25 conforming to IS : 702, 3rd and 5th layers of roofing membrane APP modified Polymeric membrane 2.0 mm thick of 3.00 Kg/sqm weight consisting of five layers prefabricated with centre core as 100 micron HMHDPE film sandwiched on both sides with polymeric mix and the polymeric mix is protected on both side with 20 micron HMHDPE film. 7th, the top most layer shall be finished with brick tiles of class designation 10 grouted with cement mortar 1:3 (1 cement : 3 fine sand) mixed with 2% integral water proofing compound by weight of cement over a 12 mm layer of cement mortar 1:3 (1 cement : 3 fine sand) and finished neat (item of laying brick tiles shall be paid for separately).	sqm	43.6		
Total (SAY L)						0.00
(iv) DISMANTLING & DEMOLISHING:-						
1	15.23	<i>Dismantling tile work in floors and roofs laid in cement mortar including stacking material within 50 metres lead.</i>				
1.1	15.23.1	For thickness of tiles 10 mm to 25 mm	sqmt	150.85		
2	15.12	<i>Dismantling doors, windows and clerestory windows</i> (steel or wood) shutter including chowkhats, architrave, holdfasts etc. complete and stacking within 50 metres lead :	No.s	15		
3	15.52	<i>Dismantling of flushing cistern of all types</i> (C.I./PVC/Vitrious China) including stacking of useful materials near the site and disposal of unserviceable materials within 50 metres lead.	no.s	4		
4	15.6	<i>Dismantling old plaster or skirting raking out</i> joints and cleaning the surface for plaster including disposal of rubbish to the dumping ground within 50 metres lead.	SQ.MT	35.6		
Total (SAY M)						0.00
(v) SUPPLY ITEMS:-						
1	Market rate	Providing & installtion of Margaret LED pendant 35W- 4000K	Nos	1		
2	Market rate	Providing & installtion of Mariah Led Pendant 24W 4000K	Nos	1		
Total (SAY N)						0.00
GRAND TOTAL (SAY O = A + B + C + D + E + F + G + H + I + J + K + L + M+N)						0.00
GRAND TOTAL INCLUDING 18% GST						0.00

Note:

- a) **During the course of execution of said work any other defect/ repair work/ extra work, not included in scope of work is observed by the contractor, is to be communicated to this office in writing.**
- b) The passenger lifts in the buildings will not be given for transportation/carriage of materials/debris of work.
- c) The quoted rate shall be workable and inclusive of all material and labour cost as well as contractor profit, overheads/Income Tax as applicable, but exclusive of GST.
- d) The contractor should have valid GST registration. While raising RA/final bills, the contractor should write their GSTIN number in the Tax Invoice and should also clearly indicate applicable SGST/CGST amounts payable. Any changes in GST rate prevailing shall be applicable on the quoted rates.
- e) The tenderers should visit site and assess site conditions and scope of work before quoting the rates.
- f) All the measurements of the work shall be recorded on Measurement Book at site, jointly by the contractor and NABARD representative.
- g) The GST applicable (i.e. 18%) for the captioned work shall be applicable as per SAC Code 995419.
- h) The L-1 agency will be decided on the basis of total amount quoted for the work in the Price Bid.
- i) The contractor has to quote for all the items of the tender. Incomplete tenders will be rejected.

DECLARATION BY THE CONTRACTOR

I/ We have read and understood all the instructions / conditions made above and we / have taken into account the above Instructions / Terms and Conditions while quoting the rates. I/ We accept all the above Terms and Conditions without any reservation, in all respects with regard to Financial Bid quoted above.

Place:

(Signature of the Tenderer)

Date:

Name and Seal: