



REQUEST FOR PROPOSAL (RFP)

From the Empanelled Consultants

For

the Selection of Consultant for the project of setting up of “Experience Centre at NABARD Head Office Building in Bandra- Kurla Complex, Mumbai.”

Last date of receipt of queries to be clarified in Pre-Bid meeting	09.01.2024
Date of Pre-Bid Meeting	10.01.2024
Release of Pre-bid clarifications	12.01.2024
Last Date of Submission of RFP	02.00 PM on 24.01.2024
Date of opening of Technical Bid	02.00 PM on 25.01.2024
Date of Design Presentation	05.02.2024 & 06.02.2024 (02.00 PM to 05.00 PM)
Date of Opening of Financial Bid	03.00 PM on 07.02.2024

DISCLAIMER

This Request for proposal (RFP) is not an offer by NABARD, but an invitation to receive response from empanelled bidders for engagement of consultant. The contents and information provided in this Request for Proposal (RFP) are meant to provide general information that may be useful to the empanelled consultants in formulation of their proposal pursuant to this RFP. The selected bidder will be required to execute an agreement with NABARD that will govern the rights, duties and obligations between NABARD and the successful bidder. Accordingly, no contractual obligation whatsoever shall arise from the RFP process unless and until a formal contract is signed and executed by NABARD with the selected bidder.

राष्ट्रीय कृषि और ग्रामीण विकास बैंक, मुंबई

**NATIONAL BANK FOR AGRICULTURE AND RURAL DEVELOPMENT,
HEAD OFFICE, MUMBAI**

संदर्भ सं. राबै/ डीपीएसपी/ एक्सपिरियन्स सेंटर/ 2208 /2023-24 दिनांक 04.01.2024

Ref No. NB/ DPSP/ Exp. Centre/ 2208 / 2023-24 dated 04.01.2024.

प्रस्ताव के लिए अनुरोध आमंत्रित करने की सूचना (आरएफपी)

कार्य का नाम: 'बान्द्रा-कुर्ला कॉम्प्लेक्स, मुंबई में नाबार्ड प्रधान कार्यालय भवन में एक्सपिरियन्स सेंटर' स्थापित करने की परियोजना के लिए सलाहकार के चयन के लिए पैनल में शामिल सलाहकारों से प्रस्ताव के लिए अनुरोध

Name of the Work: Request for Proposal from the empanelled consultants for the selection of consultant for the project of setting up of "Experience Centre at NABARD Head Office Building in Bandra- Kurla Complex, Mumbai."

1. नाबार्ड संबंधित कार्य के लिए पैनल में शामिल परामर्शदाताओं से दो बोली प्रणाली में क्यूसीबीएस (गुणवत्ता सह लागत आधारित चयन) पद्धति के तहत ऑनलाइन मोड के माध्यम से आरएफपी आमंत्रित करता है NABARD invites RFP through online mode under QCBS (Quality cum Cost Based Selection) method in two bid System from the empanelled consultants for the captioned work.
2. नाबार्ड की वेबसाइट www.nabard.org और सीपीपी के पोर्टल में आरएफपी से संबंधित दस्तावेज डाउनलोड के लिए उपलब्ध है. कोई भी दस्तावेज की भौतिक प्रतिलिपि नाबार्ड द्वारा प्रदान नहीं की जाएँ और न ही उसे प्रस्तुत की जाएँ

The RFP document is available on NABARD website www.nabard.org and CPP Portal for download. No physical copy shall be provided by NABARD and submitted to NABARD.

3. इच्छुक सूचीबद्ध परामर्शदाता अपनी तकनीकी बोली (धारा-I) और वित्तीय बोली (अनुभाग-II) के समर्थन में सभी संबंधित दस्तावेजों आदि की विधिवत हस्ताक्षरित स्कैन की गई प्रतियों के साथ अपनी बोलियां निर्धारित समय सीमा के भीतर ही वेबसाइट सीपीपीपी पोर्टल पर अपलोड कर सकते हैं. बोली का मूल्यांकन बोलीदाताओं द्वारा प्रस्तुत ऑनलाइन बोलियों पर आधारित होगा
The interested empaneled consultants can upload their bids along with duly signed scanned copies of all relevant documents etc., in support of their Technical Bid (Section-I) & Financial Bid (Section-II) on the website CPP Portal only within the prescribed time limit. The evaluation of bids will be based on online bids submitted by bidders.
4. 22-01-2024 को या उससे पहले अनुबंध । में दिए गए विवरण के अनुसार आरटीजीएस/एनईएफटी के माध्यम से 35,000/- रुपये की अग्रिम राशि नाबार्ड को प्रेषित की जानी चाहिए. आरएफपी की तकनीकी बोली के साथ इसके लिए काउंटरफॉइल/रसीद/लेन-देन का ब्यौरा संलग्न करना होगा. ईएमडी के बिना आरएफपी को उचित रूप से खारिज कर दिया जाएगा. ईएमडी पर कोई ब्याज देय नहीं है
An Earnest Money Deposit (EMD) of ₹35,000/- amount should be remitted to NABARD through RTGS/ NEFT as per the details given in Annexure I on or before 22-01-2024. Counterfoil/ receipt/transaction detail for the same

has to be enclosed with the technical bid of RFP. The RFP without EMD shall be rejected out rightly. No interest is payable on the EMD.

5. यह ध्यान दिया जाए की यह दो बोली प्रणाली निविदा होगी जिसमें पहली बोली 'तकनीकी बोली' होगी और दूसरी बोली 'वित्तीय बोली' होगी. बोलीदाताओं को सलाह दी जाती है कि वे सीपीपीपी में दर्शाए गए सिस्टम और प्रक्रियाओं से संबंधित निर्देशों का सावधानीपूर्वक पालन करने के पश्चात ही सीपीपीपी पोर्टल के माध्यम से ई-निविदा (ई-बोली) प्रस्तुत करें. ई-बोली जमा करते समय किसी और मार्गदर्शन, सहायता और समर्थन के मामले में, बोलीदाता सीपीपीपी पोर्टल पर ई-निविदा सेवाओं की सुविधा के लिए सुविधा प्रबंधन कार्मिक सुश्री त्रिशा सोनवणे से संपर्क कर सकते हैं. संपर्क विवरण निम्नानुसार उल्लिखित हैं:

It may be noted that it will be a two bids system tendering wherein the first bid will be 'Technical Bid' and second bid will be the 'Financial Bid'. Bidders are advised to submit e-tender (e-bids) through CPP Portal only, after carefully following the instructions related to systems and procedures as indicated in the CPP Portal. In case of any further guidance, help and support while submission of e-bids, bidders may contact Ms. Trusha Sonawane, a Facility Management Personnel for facilitating e-tendering services on CPP portal. The contact details are mentioned as under:

ऑनलाइन ई-निविदा समर्थन के लिए संपर्क विवरण –

Contact details for online e-tendering support –

क्र.सं. Sr.no.	व्यक्ति का नाम Name of Person	दूरभाष सं. Contact no.
1.	सुश्री त्रिशा सोनवणे Ms. Trusha Sonawane	022-26539464 (Extension-112) मोबाइल सं: Mobile No: 9967699576 e-Mail: fmp.cppp@nabard.org

6. कृपया ध्यान दें कि इलेक्ट्रॉनिक मोड के माध्यम से ई-निविदा जमा करने के लिए, इच्छुक बोलीदाताओं के पास सीपीपीपी पोर्टल लॉगिन करने के लिए डिजिटल हस्ताक्षर प्रमाण पत्र (डीएससी) होना चाहिए. Please note that to submit e-tender through electronic mode, interested bidders should have Digital Signature Certificates (DSC) to login CPP Portal.

7. तकनीकी बोली (धारा-1) अर्थात इसमें निम्नलिखित शामिल होंगे;

- क. आरएफपी आमंत्रित करने वाली सूचना
- ख. ₹35,000/- की अग्रिम धन जमा रसीद (केवल पैंतीस हजार रुपये)
- ग. बोली का प्रपत्र (आरएफपी)
- घ. बोली दस्तावेज [तकनीकी बोली]
- ङ. अनुलग्नक II से अनुलग्नक V तक

Technical Bid (Section-I) i.e., shall contain;

- a. Notice Inviting RFP
- b. Earnest Money Deposit receipt of ₹35,000/- (Rupees Thirty-Five Thousand Only)
- c. Form of Bid (RFP)
- d. Bid documents [Technical Bid]
- e. Annexure II to Annexure V

8. वित्तीय बोली (धारा-II) में निम्नलिखित शामिल होंगे:
क. परामर्श सेवाओं की विधिवत मूल्य अनुसूची.
Financial Bid (Section-II) shall contain:
a. Duly filled in Schedule of Consultancy Services.
9. बोली-पूर्व बैठक 10.01.2024 को सुबह 11.30 बजे ग्राउंड फ्लोर ए विंग - कॉन्फ्रेंस हॉल, परिसर, सुरक्षा और खरीद विभाग, नाबार्ड हेड ऑफिस मुंबई में बुलाई जाएगी. नाबार्ड से 09.01.2024 को या उससे पहले ईमेल dpsp@nabard.org द्वारा बोली पर कोई प्रश्न मांगा जा सकता है और gjb.reddy@nabard.org को प्रति भेजी जा सकती है. बोली-पूर्व बैठक के दौरान सभी प्रश्नों को स्पष्ट किया जाएगा और बोली-पूर्व बैठक की कार्यवाही 12.01.2024 को सीपीपीपी पोर्टल में अपलोड की जाएगी. बोली-पूर्व बैठक की कार्यवाही भी आरएफपी का हिस्सा होती है .

A pre-bid meeting will be convened at 11.30 AM on 10.01.2024 at Ground floor A wing - Conference Hall, Department of Premises, Security and Procurement, NABARD Head Office, BKC Mumbai. Clarifications if any on the bid may be sought from NABARD on or before 09.01.2024 by email to dpsp@nabard.org and send copy to gjb.reddy@nabard.org. All queries will be clarified during pre-bid meeting and proceedings of the pre-bid meeting will be released on 12.01.2024. Proceedings of the pre-bid clarification also forms part of the RFP.

10. आरएफपी जमा करने की अंतिम तिथि 24.01.2024 को दोपहर 02.00 बजे है. आरएफपी की तकनीकी बोली 25.01.2024 को दोपहर 02.00 बजे खोली जाएगी
Last date for submission of the RFP is 02.00 PM on 24.01.2024. Technical Bid of the RFP will be opened at 02.00 PM on 25.01.2024.
11. तकनीकी बोली के साथ ईएमडी और इंटीग्रिटी पैक्ट (आईपी) होना चाहिए. ईएमडी और आईपी के बिना बोली संक्षिप्त रूप में खारिज कर दी जाएगी. ईएमडी को अनुबंध-1 में उल्लिखित विवरण के अनुसार एनईएफटी/आरटीजीएस के माध्यम से प्रेषित किया जाना चाहिए और आईपी अनुलग्नक-11 के अनुसार प्रस्तुत किया जाना चाहिए.
Technical Bid should be accompanied by EMD and Integrity Pact (IP). The bid without EMD & IP will be summarily rejected. EMD should be remitted through NEFT/ RTGS as per the details mentioned in the Annexure-I and IP should be submitted as per Annexure-II.
12. बोली की वैधता तकनीकी बोली खोलने की तारीख से 3 महीने के लिए होगी.
Validity of the bids shall be 3 months from the date of opening of Technical Bid.
13. बोलीदाताओं से अनुरोध है कि वे आरएफपी के "चयन मानदंड" के अनुसार 05.02.2024 और 06.02.2024 (दोपहर 02.00 बजे से शाम 05.00 बजे) को प्रस्तावित एक्सपिरियन्स सेंटर की डिजाइन प्रस्तुति दें. वित्तीय बोली 07.02.2024 को दोपहर 03.00 बजे खोली जाएगी. संबंधित बोलीदाता द्वारा डिजाइन प्रस्तुति की तारीख ईमेल के माध्यम से अलग से सूचित की जाएगी।
Bidders are requested to make a design presentation of the proposed Experience Centre on 05.02.2024 and 06.02.2024 (02.00 PM – 05.00 PM) as explained under "Selection Criteria" of RFP. The date of design presentation by corresponding bidder will be intimated separately through email.
14. वित्तीय बोली 07.02.2024 को दोपहर 03.00 बजे खोली जाएगी.
Financial Bid will be opened at 03.00 PM on 07.02.2024.

15. आवेदकों को प्रोजेक्ट की डिजिटल डिज़ाइन प्रेजेंटेशन के लिए प्रस्तुत इन्वाइस पर जीएसटी सहित 50000 रुपये की एकमुश्त राशि का भुगतान किया जाएगा. उपरोक्त भुगतान पर आईटी नियम के अनुसार टीडीएस लागू होगा.
Applicants will be paid a lumpsum amount of ₹50,000/- (Rupees Fifty Thousand Only) inclusive of GST for the digital design presentation of the project as against the invoice produced. TDS as per the IT rule is applicable on the above payment.
16. डिजाइन बनाने से पहले, बोलीदाताओं को आरएफपी के "चयन मानदंड" (तकनीकी बोली का भाग 2) पर उल्लिखित साइट और स्थान का दौरा करने और स्थान के बारे में खुद आकलन करने की सलाह दी जाती है. Before making the design presentation, bidders are advised to visit the site and location as mentioned at "selection criteria" (Part II of Technical Bid) of RFP and assess themselves about the location.
17. सफल बोलीदाता को कार्य आदेश जारी होने की तारीख से 14 दिनों के भीतर आरएफपी दस्तावेज (अनुलग्नक-III) में समझौते के लेख के अनुसार गैर-न्यायिक स्टाम्प पेपर पर नाबार्ड के साथ अपनी लागत पर एक समझौता निष्पादित करना होगा, जिसमें विफल रहने पर बोलीदाता का ईएमडी जब्त हो सकता है. The successful bidder shall execute an agreement with NABARD at his cost on non-judicial stamp paper as per the article of agreement in the RFP document (Annexure-III) within 14 days from the date of issue of work order failing which the bidder's EMD may stand forfeited.
18. नाबार्ड आरएफपी दस्तावेजों में किसी भी नियम और शर्तों में संशोधन करने / वापस लेने या बिना कोई नोटिस दिए या कोई कारण बताए किसी भी या सभी आरएफपी को अस्वीकार करने का अधिकार सुरक्षित रखता है. नाबार्ड के पास बिना कोई कारण बताए किसी भी या सभी बोलियों को पूर्ण या आंशिक रूप से स्वीकार या अस्वीकार करने का अधिकार भी सुरक्षित है. NABARD reserves the right to amend / withdraw any of the terms and conditions in the RFP Documents or to reject any or all RFP without giving any notice or assigning any reason thereof. NABARD also reserves the right to accept or reject any or all bids in full or part without assigning any reason whatsoever.

भवदीय

Yours faithfully

Sd/-

(A K Pittan)

Deputy General Manager

Department of Premises Security and Procurement

B-Wing, Ground Floor

National Bank for Agriculture and

Rural Development (NABARD)

C-24, G-Block, BKC, Bandra(E)

Mumbai-400 051

FORM OF RFP

To,

Date:

The Chief General Manager,

Department of Premises, Security and Procurement

National Bank for Agriculture and Rural Development

Head Office, Mumbai – 400051

Dear Sir,

Request for Proposal from the empanelled consultants for the selection of consultant for the project of setting up of “Experience Centre at NABARD Head Office Building, Mumbai.”

1. Having examined the RFP document relating to the works specified in the Memorandum hereinafter set out, having visited and examined the site of the works specified in the said memorandum and having acquired the requisite information relating thereto as affecting the bid, I/We hereby offer to execute the services specified in the said memorandum within the time specified, at the rates mentioned in the Financial Bid in all respects of the bid and with such materials as are provided for, in accordance with such conditions in so far as they may be applicable.

2. Memorandum

S. No	Key Components	Details
1	Name of the Project	“Request for Proposal from the empanelled consultants for the selection of consultant for the project of setting up of Experience Centre.
	Location	NABARD Head Office Building, Mumbai
2	Bid issued by	NABARD
3	Procurement Stage	Two Stage <ul style="list-style-type: none">• Technical Bid (Section-I)• Financial Bid (Section-II)
4	Earnest Money Deposit (EMD)	₹ 35,000/- (Rupees Thirty-Five Thousand Only)

3. Should this bid be accepted, I/We hereby agree to abide by and fulfil the terms and conditions of the bid annexed hereto.

Our Bankers are:

i) Bank, Branch,, Mumbai

ii) Bank, Branch,, Mumbai

iii) Type of account: Savings / Current account

iv) Bank Account No:

v) IFS code of Bank and branch:

The names of partners of our firm are:

i)

ii)

iii)

Name of the partner of the firm

Authorized to sign:

OR

Name or person having Power of

Attorney to sign the contract

(Certified copy of the Power of
Attorney should be attached):

Yours faithfully,

Signature of Bidder with stamp

TABLE OF CONTENTS

TECHNICAL BID [Section-I]

Part I	: Background Information
Part II	: General Terms, Conditions and Instructions
Part III	: Additional Terms and Conditions
Part IV	: Format of Virtual Completion Certificate
Annexure I	: Proforma of EMD credit details
Annexure II	: Pre-Contract Integrity Pact
Annexure III	: Articles of Agreement
Annexure IV	: Proforma for furnishing the payment details of Bidder
Annexure V	: Location Layout of Proposed Experience Centre

Financial Bid [Section-II]

Part I: Background Information

1. About NABARD:

National Bank for Agriculture and Rural Development (NABARD) was established on 12 July 1982 by an Act of the Parliament. NABARD is an AIFI (All India Financial Institution) of GOI. NABARD is mandated for providing effective credit support, institutional development and technology support, small scale industries, cottage and village industries, handicrafts and other rural crafts and other allied economic activities in rural areas with a view to promote integrated rural development and securing prosperity of rural areas, and for matters connected therewith or incidental thereto.

NABARD, with its Head office at Mumbai (Bandra-Kurla Complex), has 31 Regional Offices located in States and Union Territory, a cell at Srinagar, 04 Training Establishments in the Northern, Eastern & Southern parts of India and 423 District Development Managers (DDMs) functioning at district level.

2. Proposed Experience Centre at NABARD:

(i) Brief Description: Experience Centre is a facility that provides visitors with an immersive and interactive experience of the various initiatives and programs undertaken by an organisation. The proposed Experience Centre at NABARD Head Office building aims to showcase the roles and achievements of NABARD in promoting overall development of agriculture and rural sectors in the country and NABARD's endeavour for future development to realise its vision as Development Bank of the nation.

The core objective of the Experience Centre at NABARD Head Office Building is to demonstrate the importance of 'NABARD as an institution' in the all-round development of the rural economy of the country. By doing so, the visitors across multiple demographics would be inspired to contribute towards agriculture and rural development of the country. The Experience Centre would also serve as a learning station and a referral centre for NABARD's Staff. The Centre's facilities can also be used as a media for training purpose of new recruits of NABARD.

(ii) The tentative equipment to be installed are as under:

- Info-fountains
- Large Format Displays (LFDs)
- Touch Screen Kiosks
- Interactive display board with active LED
- Digital Signage LED unit with specified size of manufacturer and Custom based LED video wall.

(iii) Category of Visitors at NABARD HO:

Typically, 03 types of visitors are expected to visit the Experience Centre which are given below:

- (a) Clients: Banks, State Govt/ Depts, Central Govt. Depts, Developmental Partners such as NGO's, Prospective Investors and Business Visitors.
- (b) Dignitaries (e.g., Ministers, Govt. Officers, International Developmental Agencies, Multilateral Development Banks etc.)
- (c) Employees

The Content Management System (CMS) software application for the Experience Centre should be prepared to address the requirements of the above.

Part II: General Terms, Conditions, and Instructions

I. Selection Criteria for the bidder/ consultant

1. All applicants should execute Integrity Pact (IP) as per the format (**Annexure II**) on non-judicial stamp paper of ₹200/-. The application without the IP will be summarily rejected.
2. The location for the proposed Experience Centre is at the main entrance hall starting “from the area of visitor’s room to the scanning area spreading about 800 sq. ft” (available headroom is 8.5 ft) on the ground floor at NABARD Head Office building, BKC, Mumbai. The layout of the location is in the **Annexure V** for reference.
The applicant should prepare the layout, architectural design and drawings with 2D and 3D views along with functional planning of the digital equipment of the proposed Experience Centre.
3. Based on the above design, the bidder/ consultant should make design presentation of the project including 3D walkthrough, clearly showing the positioning of digital equipment, explaining their functions and utility according to the client needs and expectations in line with the mandate of NABARD. Applicants may refer NABARD website for an idea of various activities undertaken by NABARD.
If the bidder or his associated resource personnel have any past experience in designing and executing Experience Centre, a presentation of that Experience Centre may also be done.
4. The selection of the consultant will be based on QCBS selection process with 70% weightage on design presentation in the technical bid and 30% weightage on price bid as mentioned in the evaluation criteria.
5. The applicant who is securing maximum marks in Technical Bid and Financial Bid together will be awarded the consultancy of the project.

Note:

- i) Applicants will be paid a lumpsum amount of ₹50,000/- (Rupees Fifty Thousand Only) inclusive of GST for the digital design presentation of the project as against the invoice produced. TDS as per the IT rule is applicable on the above payment. Applicants should furnish the payment details as per the relevant format (**Annexure IV**) in the RFP.
- ii) After presentation, physical and digital copies of drawings including 3D walkthrough should be handed over to NABARD. NABARD will be the sole

owner of these physical and digital drawings for use as per the requirement and no claim from the consultants in this regard will be entertained.

II. Evaluation Criteria

Bids shall be evaluated both in terms of 'Quality' as well as 'Quoted Price' i.e., Quality Cum Cost Based Selection (QCBS) methodology. The weightage for the 'Quality' is 70 % and the weightage for the 'Quoted Price' is 30 %

The maximum marks to be allocated against various sub-sections under '**Quality Part of Selection Criteria**' of Bid shall be as hereunder:

1. Technical Evaluation of Design:

SI. No	Criteria	Marking Evaluation	Max Marks
1	Design Presentation	I. Digital Presentation of Experience Centre already executed if any by the bidder or his associated resource personnel.	20
		II. Design Presentation of the Proposed Experience Centre: <ul style="list-style-type: none"> • Approach and Methodology. • Layout Plan. • Interior plan elaborating how interior work will be designed and how it is to be shown. • Digital equipment installation design with functional planning and detailed explanation of their functionalities. • Overall 3D walkthrough of interior design and digital equipment installation. • Expected timelines with major milestones for different stages of the work and project as a whole as per the scope of work outlined in the RFP. 	50

Technical Score of the bidders will be evaluated using the following formula.

$$\text{Technical Score} = (T \times 70) / T \text{ (high)}$$

where T stands for actual marks secured by the bidder and T (high) stands for highest marks secured by the bidder in the presentation.

Technical score shall be calculated up to two decimal places.

2. Evaluation of Financial Bid:

Financial score of the bidders will be evaluated using the following formula.

$$\text{Financial Score} = [(L1 \times 30) / (L)].$$

Where L1 stands for lowest rate quoted by the bidder and L stands for rate quoted by the bidder.

Financial Score shall be calculated up to two decimal places.

3. Combined Evaluation of Technical & Financial Bids:

- i. The technical and financial scores of each bidder will be added to compute a composite bid score.

$$\text{Composite bid score} = \text{Technical score} + \text{Financial Score}$$

- ii. **The bidder securing the highest composite bid score will be selected for awarding the consultancy work.**
- iii. In the event of two or more bids having the same highest composite bid score, the bid scoring the highest marks against 'Quality' criteria (Design Presentation) will be recommended for awarding the consultancy assignment.
- iv. In the event of two or more bids having the same highest marks against 'Quality' criteria, then the bidder having higher experience will be recommended for awarding the consultancy assignment.

III. Scope of Services to be rendered by the Consultant:

1. Providing Comprehensive Architectural Consultancy Services for the interior designing for the proposed "Experience Centre". The location for the proposed Experience Centre is at the main entrance hall starting "from the area of visitor's room to the scanning area spreading about 800 sq. ft" on the ground floor at NABARD Head Office building, BKC, Mumbai. The layout of the location is in the **Annexure V** for reference.
2. Taking NABARD's instructions and after visiting the site and carrying out detailed survey and investigations; preparing 2-D & 3-D detailed sketch with dimensions, preparing 3-D walk through of the proposed designs along with functional design and arrangement of equipment's by the consultant envisaged for the Experience Centre.
3. Advising NABARD after consultation for selection of suitable digital equipment, to be installed in the upcoming "Experience Centre".
4. Guide and support the system integrator to develop the technology, Content Management System (CMS) software application and other relevant software

- suitable for digital display units as per the latest trend and technology presently used in the reputed experience centres domestically and globally.
5. Preparation of draft comprehensive design and drawings of the interior area and functional arrangements of equipment meant for the upcoming Experience Centre. The designs should be modern, eye catching and attractive to a wide variety of audience.
 6. Preparing plans with alternative schemes, preparing presentations wherein the details of the scheme shall be explained in detail before officials and/ or senior management of NABARD. Any doubt that may arise thereof shall be clarified and changes, if any, suggested in the proposed design may be incorporated or deleted as found suitable, to meet the requirements of NABARD and to enable NABARD to select the design and the scheme.
 7. Preparation of final comprehensive design and drawings (including 2D & 3D drawings) of the interior area and functional arrangements of equipment meant for the proposed Experience Centre.
 8. Preparation of walk-through of finalised design and present it before the concerned senior officials of NABARD.
 9. Preparation of comprehensive draft BOQ for interior works, Supply, Installation, Testing and Commissioning of equipment for Experience Centre.
 10. Preparing preliminary project cost estimate with detailed specifications on the final design and scheme and preparing report on the merits of the selected scheme, to enable NABARD to take a decision on the designs and the scheme as a whole and approve the same.
 11. Preparing final BOQ of the project with cost estimate and detailed specifications and also rate analysis after incorporating necessary corrections, if any, as suggested by NABARD based on draft BOQ and preliminary estimate.
 12. Conducting discussions/ deliberations/ presentations, etc. with officials/ top management/ representatives of NABARD with respect to the project.
 13. Facilitating visits to other Experience Centres and/ or setups of similar nature for cross learning as and when needed and carrying out necessary liaison with their officials as per the requirement during design and implementation stage.
 14. Liaison and discussions with various Departments/ subsidiaries of NABARD for obtaining necessary information/ data and finalizing contents for displaying in the Experience Centre.
 15. After approval of estimated project cost by NABARD, preparing the draft tender documents for selection of contractor for interior work as well as for selection of system integrator for Supply, Installation, Testing and Commissioning of Digital Equipment separately for the proposed Experience Centre.
 16. After approval of draft tender documents by NABARD, preparing the tender documents for Interior works as well as for Supply, Installation, Testing and Commissioning of Digital Equipment separately for the proposed Experience Centre.
 17. Assist NABARD during tendering process and for selection of contractors/ vendors for Interior works as well as for selection of system integrator for Supply,

Installation, Testing and Commissioning of Digital Equipment for the Experience Centre.

18. Extend the guidance and support to the selected system integrator for developing the Content Management System (CMS) software application with liaison and by collecting data/ information collected from various departments of NABARD and as per the requirements of NABARD.
19. Arranging for developing any other software through system integrator as per the requirement for the desired results of the project.
20. Perform the duty of project management consultant with day-to-day monitoring of interior works and installation of equipment in liaison with interior contractors and system integrators at site and update NABARD about progress of the project periodically.
21. Ensure the quality and workmanship of the various elements of the project during implementation and report to NABARD.
22. Arrange progress review meetings at fortnight interval between NABARD officials and interior contractors/ system integrator, preparation of the minutes of the meetings and circulate the minutes to all the concerned parties for compliance.
23. Appoint qualified technical personnel(s) at site at consultant's own cost and risk, for day-to-day supervision, quality control, project management, receiving instruction from NABARD/ Consultant for compliance, taking and recording measurements and verifying the bills submitted by the contractor at site.
24. Certifying the bills submitted by the contractors/ system integrator and recommending to NABARD for eligible payment to them.
25. Issuing virtual completion certificate after completion of project and submitting the final sets of 2D drawing of the completed work (as built drawings) with soft copies.
26. Engaging the services of well-qualified specialists or consultants pertaining to the services relevant to the work at Consultant's own risk and cost. *No extra payment shall be made by NABARD in this regard.*
27. Coordinate activities for achieving the milestones of each stage of execution by ensuring quality control of the project as a whole.
28. Any other services incidental to or connected with the said works usually and normally rendered by architect and not referred to in any of the items referred to above.

The duties and functions of the Architects/ Consultants mentioned above are only indicative and not exhaustive.

IV. Payment Terms and Conditions

The payment will be made as per the following terms on production of the requisite documents. No advance payment would be made. Payment would be made to the consultant based on satisfactory performance of work at NABARD as per the details given below:

Phase I:

Milestone	Percentage of total fee payable
After final submission of concept design plan, drawings, preliminary estimates and the detailed project report of the proposed Experience Centre and approval of the same by NABARD. ₹50,000/- paid for design presentation during the technical bid stage shall be deducted from fee payable at this stage and balance if any shall be adjusted in the subsequent fees payable to the consultant.	10%
After preparation and submission of final tender documents for “Interior works and Supply, Installation, Testing and Commissioning of Digital Equipment for Experience Centre” and after approval by NABARD.	10%
After Scrutiny of bids/ selection of the system integrator/ contractor/vendor and after acceptance of work order by the system integrator/ contractor/vendor.	10%

Phase II:

Milestone	Percentage of total fee payable
After successful completion of about 50% work (i.e., based on settlement of bill cumulatively valued at 50% of the tender cost) as awarded to the contractor and after certification of contractor’s bill by the consultant to that extent. [Bill at this stage shall be payable and adjusted suitably based on the awarded cost of the work to the contractor]	20%
After successful completion of entire work as awarded to the contractor and after certification of final bill of the contractor by the consultant. (i.e., based on virtual completion certificate issued by the bidder/ consultant and after its approval by NABARD) [Bill at this stage shall be payable and adjusted suitably based on the actual executed cost of the work by the contractor]	40%
After completion of Defect Liability Period (one Year from the date of virtual completion of the project) after the contractor has rectified the defects observed and confirmed by consultant and approved by NABARD during DLP (Defect Liability Period).	10%

Part III: Additional Terms and Conditions

Following additional terms and conditions shall apply to the evaluation process:

- 1. Bidder warranties** - By submitting a response, bidder represents and warrants to NABARD that, as on the date of submission:
 - i. The bidder has fully disclosed to NABARD in its responses all information which could reasonably be regarded as affecting in any way NABARD's evaluation of the response.
 - ii. All the information contained in the Bidder's Response is true, accurate, complete, and not misleading in any way.
 - iii. No litigation, arbitration or administrative proceeding is presently taking place in the name of bidder.
 - iv. No litigation, arbitration or administrative proceeding is pending or to the knowledge of the bidder threatened against or otherwise involving the bidder which could have an adverse effect on its business, assets, or financial condition or upon NABARD's reputation if the response is successful.
 - v. The bidder will immediately notify NABARD of the occurrence of any event, fact or circumstance which may cause a material adverse effect on the bidder's business, assets or financial condition, or NABARD's reputation or render the bidder unable to perform its obligations under the agreement, if any or have a material adverse effect on the evaluation of the responses by NABARD; and
 - vi. The bidder has not and will not seek to influence any decisions of NABARD during the evaluation process or engage in any uncompetitive behaviour or other practice which may deny legitimate business opportunities to other bidders.
- 2. Confidentiality** - Bidder must keep confidential any information received from or about NABARD as a result of or in connection with the submission of the response. All information contained in the response, or in subsequent communications shall be deemed confidential and may be used only in connection with the preparation of bidder's response. Unless expressly agreed in writing prior to submissions, responses are not confidential and may be used by NABARD in whole or part. NABARD, however, will not disclose the information provided by bidder in a response other than to its affiliates or to its professional advisors, unless required otherwise by any provisions of law.
- 3. Disclaimer** - While all reasonable care has been taken in compiling this response document, the figures, documents, and details are presented in good faith; and no warranty or guarantee (express or implied) is given by NABARD as to the completeness or accuracy of the response or any information provided in or in connection with it. To the maximum extent permitted by law:

- a. NABARD, its officers, employees, and agents will not be liable in any way whatsoever for any loss, damage, cost, or expense (including without limitation any liability arising from any fault or negligence on their part) arising from the evaluation process; and
 - b. Each bidder releases and indemnifies NABARD from all claims, suits, demands, proceedings, actions, liabilities, damages, and costs which may arise under statute, law, equity or otherwise arising from, whether directly or indirectly, or in connection with the evaluation and selection process.
- 4. NABARD's right to verify** - NABARD reserves the right to conduct survey of any of the bidders' sites or obtain other evidence of facilities, resources, and managerial, financial and bidder performance abilities prior to announcing the successful bidder or awarding an agreement under this evaluation process.
- 5. Termination / suspension of evaluation process** - NABARD reserves the right to suspend or terminate the bidder evaluation process (in whole or in part) at any time in its absolute discretion and without liability to the bidder or any third party. Bidders will be notified if any suspension or termination occurs, but NABARD is not obliged to provide any reasons.
- 6. Other Rights** - Without limiting its rights under any other clause of this evaluation process or at law, and without liability to the bidder or any third party, NABARD may at any stage of the evaluation process:
 - (i) Request additional information from the bidder.
 - (ii) Change the structure and timing of evaluation process.
 - (iii) Vary or extend the timetable of the evaluation process.
 - (iv) Vary the terms and conditions of the evaluation process.
- 7. Non-Reliance by Bidder** - Bidder, by submitting a response acknowledges that:
 - (i) It does not rely on any information, representation, or warranty, whether oral or in writing or arising from other conduct, other than that specified in this RFP or otherwise provided by NABARD in writing.
 - (ii) It has made its own inquiries as to regarding the risks, contingencies and other circumstances that may have an effect on the bidder's response as well as the accuracy, currency or completeness of such information; and
- 8. Precedence of Documents** - If there is any inconsistency between the terms of this RFP and any of its appendices, schedules, or attachments then, unless the contrary is explicitly stated in this RFP, the terms of the RFP will prevail to the extent of any inconsistency.
- 9. Earnest Money, Initial Security Deposit and Retention Money Deposit**
 - i) **Earnest Money Deposit** - The bidder must submit his bid with Earnest Money Deposit of ₹35,000/- (Rupees Thirty-five thousand Only) in the form of Direct Deposit in the Bank through NEFT/ RTGS and submit a copy of transaction receipt along with the technical bid. Bids not accompanied by

EMD shall be rejected. Should the Invitation to RFP be withdrawn or cancelled by the Bank, which shall have the right to do so at any time, EMD will be returned. EMD of the unsuccessful bidder will be returned after award of the work to successful bidder.

- ii) **Security Deposit** - The EMD submitted by the successful bidder with whom the agreement is executed, shall be reckoned as security deposit. No interest shall be paid on this security deposit. EMD / Security Deposit will be forfeited if the bidder withdraws the contract after award or opening of tender with the reasons only pertaining to the bidder and in the case if bidder is violating the conditions of contract which leads to termination of the contract. The security deposit will be returned to the bidder/ consultant after installation, testing and commissioning of equipment's and completion of project in all aspects and after defect liability period (DLP)

10. Signing of Contract Agreement:

- i. The general instructions to the bidder and special conditions, herein before referred to, Conditions of Contract and payment terms, scope of works enclosed with this document and the subsequent correspondence exchanged between NABARD and the bidder shall be the basis of the Purchase Order/final contract to be entered into with the successful bidder.
- ii. The bidder shall go through the terms and conditions given herewith and his offer shall be strictly in line with the terms specified therein. No deviation from the terms and conditions specified shall be acceptable.
- iii. On receipt of intimation from NABARD of the acceptance of his/their bid, the successful bidder shall be bound to implement the Contract and within 14 days thereof, the successful bidder shall sign an agreement in accordance with the articles of agreement. Notwithstanding the signing of the agreement, the written acceptance by NABARD of a bid in itself will constitute a binding contract between NABARD and the person so bidding, whether such agreement is or is not subsequently executed. The stamp duty charges will be borne by the consultant.
- iv. The bidder shall not sublet any portion of the work except with the written consent of NABARD. In case of breach of these conditions, NABARD may serve a notice in writing on the bidder rescinding the contract whereupon the security deposit shall stand forfeited to NABARD, without prejudice to his other remedies against the bidder.

11. Pre-Contract Integrity Pact - Bidder may ensure to execute a pre-contract integrity pact (duly stamped) as per **Annexure II** of RFP along with the bid which is required as per directions of the Central Vigilance commission.

Important Note - Prospective bidders are requested to submit a duly signed and stamped 'Integrity Pact' on a Rs. 200/- Stamp Paper. Compliance to 'Integrity Pact' is mandatory and shall be the pre-qualification criteria. Non-submission of 'Integrity Pact' or submission in different format (other than the prescribed one)

and not duly authenticated by authorized signatory shall disqualify the prospective bidder at the initial stage and their 'Technical/ Price' bids shall not be opened.

12. Governing Laws and Dispute Resolution - The RFP and selection process shall be governed by and construed in accordance with the laws of India and shall be subject to exclusive jurisdiction of courts in Mumbai only. Disputes or differences whatsoever, arising out of the RFP process shall be resolved hereunder:

- (i) All disputes and differences of any kind whatsoever, arising out of or in connection with the RFP (to be executed with the successful bidder at subsequent stage) shall be resolved amicably.
- (ii) In case of failure to resolve the disputes and differences amicably within 30 days of the receipt of notice by the other party, then such unsettled dispute or difference shall be referred to arbitration by sole arbitrator mutually agreed in accordance with the Arbitration and Conciliation Act, 1996.
- (iii) If no agreement is arrived at within 30 days from the date of notice as to who shall be the sole arbitrator, NABARD shall send to the bidder a list of three names of persons who shall be presently unconnected with NABARD. Bidder/ Consultant shall on receipt of the names as aforesaid, select any one of persons so named to be appointed as sole arbitrator and communicate his name to NABARD within 30 days on receipt of the names. NABARD shall thereupon without delay appoint the said person as the sole arbitrator.
- (iv) If the bidder fails to select the person as sole arbitrator within 30 days of receipt of the panel and inform NABARD accordingly, NABARD shall be entitled to appoint one of the persons from the panel as sole arbitrator and communicate his name to the bidder.
- (v) If the person so appointed is unable or unwilling to act or refuses his appointment or vacates his office due to any reason whatsoever, another person shall be appointed by NABARD from the above list of persons. The provisions of the Indian Arbitration and Conciliation Act, 1996, shall govern the arbitration.
- (vi) The award shall be final and binding on both the parties.
- (vii) It is hereby agreed that in all disputes referred to the Arbitration, the Arbitrator shall give a separate award in respect of each dispute or difference in accordance with the terms of reference and the award shall be a reasoned award. It is hereby agreed that the Arbitrator shall not have powers to order any interim measures whatsoever during the course of arbitration.
- (viii) The fees, if any, of the Arbitrator shall initially be paid in equal proportion by each of the parties. The cost of the reference and of the award including the fees, if any, of the Arbitrator shall be directed to be finally borne and paid by such party or parties to the dispute in such

manner or proportion as may be directed by the Arbitrator as the case may be in the award.

- (ix) The place of arbitration shall be at Mumbai.
- (x) The language of the proceedings shall be in English.

(xi) **Services shall continue to be rendered not withstanding any reference or dispute to the arbitration:**

It is specially agreed that the bidder/ consultant shall continue to render its services provided herein with all due diligence, professional skill, and tact notwithstanding that any matter, question or dispute has been referred to arbitration.

Accepted all terms & conditions.

Date:-

Place:-

(Signature)

Name, address and seal of the consultant

Part IV: Format of VIRTUAL COMPLETION CERTIFICATE to be issued by the Consultant.

Having executed the work in terms of the tender, we hereby certify and affirm that the Contractor/ System Integrator M/s..... have virtually completed the contracted works.

We hereby certify that the work has been executed completely to our satisfaction and with materials, workmanship and specifications in accordance with the tender.

We do certify further that the Contractor/ System Integrator executed the work in accordance with the applicable laws and without any transgression of such laws.

Signature of the Consultant:

Place :

Date :

Name :

Address :

Proforma of EMD credit details

RFP from the empanelled consultants for the selection of consultant for the project of setting up of Experience Centre at NABARD Head Office Building in Bandra Kurla Complex, Mumbai

(EMD details to be filled by bidders)

NAME OF THE ACCOUNT	NATIONAL BANK FOR AGRICULTURE AND RURAL DEVELOPMENT
BANK NAME	NABARD
BRANCH NAME	HEAD OFFICE, MUMBAI
IFSC CODE	NBRD0000002
ACCOUNT NUMBER (VAN)	NABADMN07

Name of the depositor	
Mode of transfer – Online (NEFT / RTGS)	
UTR No.	
Transaction date	
Amount deposited	
** Attach Bank Statement showing amount debited from account, on or before last date of submission of RFP.	

Date:

Place:

Signature with seal:

PRE-CONTRACT INTEGRITY PACT

(To be submitted On Rs. 200/- non-judicial stamp paper)

General

This pre-bid pre-contract Agreement (hereinafter called the Integrity Pact) is made on _____ day of the month of _____ between, on one hand, National Bank for Agriculture and Rural Development (NABARD), represented by Shri _____, CGM, NABARD, DPSP, NABARD, HO , Mumbai hereinafter called the “Employer”, which expression shall mean and include, unless the context otherwise requires, his successors in office and assigns) of the First Part and M/s _____ represented by Shri _____, Chief Executive Officer (hereinafter called “Bidder” which expression shall mean and include, unless the context otherwise requires, his successors and permitted assigns) of the Second Part.

WHEREAS the Employer proposes to carry out the work of “_____” and the Bidder is willing to offer/ has offered the quotes and

WHEREAS THE Bidder is a private company/ public company/ Government undertaking/ partnership/ registered export agency, constituted in accordance with the relevant law in the matter and the Employer is a body corporate established under NABARD Act, 1981 having its Head Office at Plot No. C-24, Block ‘G’, Bandra-Kurla Complex, Bandra (East), Mumbai.

NOW, THEREFORE,

To avoid all forms of corruption by following a system that is fair, transparent, and free from any influence/ prejudiced dealings prior to, during and subsequent to the currency of the contract to be entered into with a view to:

Enabling the Employer to obtain the desired said stores/ equipment at a competitive price in conformity with the defined specifications by avoiding the high cost and the distortionary impact of corruption on public procurement and

Enabling Bidders to abstain from bribing or indulging in any corrupt practice in order to secure the contract by providing assurance to them that their competitors will also abstain from bribing and other corrupt practices and the EMPLOYER will commit to prevent corruption, in any form, by its officials by following transparent procedures.

The parties hereto hereby agree to enter into this Integrity Pact and agree as follows:

Commitments of the Employer

1.1 The Employer undertakes that no official of the Employer, connected directly or indirectly with the contract, will demand, take a promise for or accept, directly or

through intermediaries, any bribe, consideration, gift, reward, favour or any material or immaterial benefit of any other advantage from the BIDDER, either for themselves or for any person, organization or third party related to the contract in exchange for an advantage in the bidding process, bid evaluation, contracting or implementation process related to the contract.

1.2 The Employer will, during the pre-contract stage, treat all BIDDERS alike and will provide to all BIDDERS the same information and will not provide any such information to any particular BIDDER, which could afford an advantage to that particular BIDDER in comparison to other BIDDERS.

1.3 All the officials of the EMPLOYER will report to the appropriate Government office any attempted or completed breaches of the above commitments as well as any substantial suspicion of such a breach.

2. In case any such preceding misconduct on the part of such official(s) is reported by the BIDDER to the EMPLOYER with full and verifiable facts and the same is prima facie found to be correct by the EMPLOYER, necessary disciplinary proceedings, or any other action as deemed fit including criminal proceedings may be initiated by the EMPLOYER and such a person shall be debarred from further dealings related to the contract process. In such a case while an enquiry is being conducted by the EMPLOYER the proceedings under the contract would not be stalled.

Commitment of BIDDERS

3. The BIDDER commits itself to take all measures to prevent corrupt practices, unfair means and illegal activities during any stage of its bid or during a pre-contract or post-contract stage in order to secure the contract or in furtherance to secure it and in particular commit itself to the following: -

3.1 The BIDDER will not offer, directly or through intermediaries, any bribe, gift, consideration, reward, favour, any material immaterial benefit or other advantage, commission, fees, brokerage or inducement to any official of the EMPLOYER, connected directly or indirectly with the bidding process, or to any person, organization or third party related to the contract in exchange for any advantage in the bidding, evaluation, contracting and implementation of the contract.

3.2 The BIDDER further undertakes that it has not given, offered or promised to give, directly or indirectly any bribe, gift, consideration, reward, favour, any material or immaterial benefit or other advantage, commission, fees, brokerage or inducement to any official of the EMPLOYER or otherwise in procuring the Contract or forbearing to do or having done any act in relation to the obtaining or execution of the contract or any other contract with the Bank for showing or forbearing to show favour or disfavour to any person in relation to the contract or any other contract with the Bank.

3.3 BIDDERS shall disclose the name and address of agents and representatives and Indian BIDDERS shall disclose their foreign principles or associates.

3.4 BIDDERS shall disclose the payments to be made by them to agents/ brokers or any other intermediary, in connection with this bid/ contract.

3.5 The BIDDER further confirms and declares to the EMPLOYER that the BIDDER is the original manufacturer/ integrator/ authorized government sponsored export entity of the defence stores and has not engaged any individual or firm or company whether Indian or foreign to intercede, facilitate or in any way to recommend to the EMPLOYER or any of its functionaries, whether officially or unofficially to the award of the contract to the BIDDER, nor has any amount been paid, promised or intended to be paid to any such individual, firm or company in respect of any such intercession, facilitation or recommendation.

3.6 The BIDDER, either while presenting the bid or during pre-contract negotiations or before signing the contract, shall disclose any payments he has made, is committed to or intends to make to officials of the EMPLOYER or their family members, agents, brokers or any other intermediaries in connection with the contract and the details of services agreed upon for such payments.

3.7 The BIDDER will not collude with other parties interested in the contract to impair the transparency, fairness, and progress of the bidding process, bid evaluation, contracting and implementation of the contract.

3.8 The BIDDER will not accept any advantage in exchange for any corrupt practice, unfair means and illegal activities.

3.9 The BIDDER shall not use improperly for purposes of competition or personal gain or pass on to others, any information provided by the EMPLOYER as part of the business relationship regarding plans, technical proposals and business details, including information contained in any electronic data carrier. The BIDDER also undertakes to exercise due and adequate care lest any such information is divulged.

3.10 The BIDDER commits to refrain from giving any complaint directly or through any other manner without supporting it with full and verifiable facts.

3.11 The BIDDER shall not instigate or cause to instigate any third person to commit any of the actions mentioned above.

3.12 If the BIDDER or any employee of the BIDDER or any person acting on behalf of the BIDDER either directly or indirectly is a relative of any of the officers of the EMPLOYER, or alternatively if any relative of an officer of the EMPLOYER has financial interest/ stake in the BIDDER's firm, the same shall be disclosed by the BIDDER at the time of filling of tender.

The term 'relative' for this purpose would be as defined in Section 6 of the Companies Act 1986.

3.13 The BIDDER shall not lend to or borrow any money from or enter into any monetary dealings or transactions, directly or indirectly, with any employee of the EMPLOYER.

4. Previous Transgression

4.1 The BIDDER declares that no previous transgression occurred in the last three years immediately before signing of this Integrity Pact, with any other company in any country in respect of any corrupt practices envisaged hereunder or with any Public Sector Enterprises in India or any Government Department in India that could justify BIDDER's exclusion from the tender process.

4.2 The BIDDER agrees that if it makes incorrect statement on this subject, BIDDER can be disqualified from the RFP process or the contract, if already awarded, can be terminated for such reason.

5. Earnest Money Deposit (Security Deposit)

5.1 While submitting commercial bid, the BIDDER shall deposit an amount Rs. _____ as Earnest Money/ Security Deposit, with the EMPLOYER through online in favour of NABARD

5.2 The Earnest Money/ Security Deposit shall be valid up to a period of one year or the complete conclusion of the contractual obligations to the complete satisfaction of both the BIDDER and the EMPLOYER, including defect liability period, whichever is later.

5.3 In case of the successful BIDDER a clause would also be incorporated in the Article retaining to Performance Bond in the Purchase Contract that the provisions of Sanctions for Violation shall be applicable for forfeiture of Performance Bond in case of a decision by the EMPLOYER to forfeit the same without assigning any reason for imposing sanction for violation of this Pact.

5.4 No interest shall be payable by the EMPLOYER to the BIDDER on Earnest Money/ Security Deposit for the period of its currency.

6. Sanctions for Violations

6.1 Any breach of the aforesaid provisions by the BIDDER or anyone employed by it or acting on its behalf (whether with or without the knowledge of the BIDDER) shall entitle the EMPLOYER to take all or any one of the following actions, wherever required:

To immediately call off the pre-contract negotiations without assigning any reason or giving any compensation to the BIDDER. However, the proceedings with the other BIDDER(s) would continue.

The Earnest Money Deposit (in pre-contract stage) and/ or Security Deposit/ Performance Bond (after the contract is signed) shall stand forfeited either fully or

partially as decided by the EMPLOYER and the EMPLOYER shall not be required to assign any reason thereof.

To immediately cancel the contract, if already signed, without giving any compensation to the BIDDER.

To recover all sums already paid by the EMPLOYER, and in case of an Indian BIDDER with interest thereon at 2% higher than the prevailing Prime Lending Rate of State Bank of India, while in case of a BIDDER from a country other than India with interest thereon at 2%, higher than the LIBOR. If any outstanding payment is due to the BIDDER from the EMPLOYER in connection with another contract for any other stores, such outstanding payment could also be utilized to recover the aforesaid sum and interest.

To encash the advance bank guarantee and performance bond/ warranty bond, if furnished by the BIDDER, in order to recover the payments, already made by the EMPLOYER, along with interest.

To cancel all or any other contracts with BIDDER. The BIDDER shall be liable to pay compensation for any loss or damage to the EMPLOYER resulting from such cancellation/ rescission and the EMPLOYER shall be entitled to deduct the amount so payable from the money(s) due to the BIDDER.

To debar the BIDDER from participating in future bidding processes of the Government of India for a minimum period of five years, which may be further extended at the discretion of the EMPLOYER.

To recover all sums paid in violation of this Pact by BIDDER(S) to any middleman or agent or broker with a view to securing the contract.

In cases where irrevocable Letters of Credit have been received in respect of any contract signed by the EMPLOYER with the BIDDER, the same shall not be opened.

Forfeiture of Performance Bond in case of a decision by the EMPLOYER to forfeit the same without assigning any reason for imposing sanction for violation of this Pact.

6.2 The EMPLOYER will be entitled to take all or any of the actions mentioned at para 6.1(i) to (x) of this Pact also on the Commission by the BIDDER or any one employed by it or acting on its behalf (whether with or without the knowledge of the BIDDER), of an offence as defined in Chapter IX of the Indian Penal code, 1860 or Prevention of Corruption Act, 1988 or any other statute enacted for prevention of corruption.

6.3 The decision of the EMPLOYER to the effect that a breach of the provisions of the Pact has been committed by the BIDDER shall be final and conclusive on the BIDDER. However, the BIDDER can approach the Independent Monitor(s) appointed for the purposes of this Pact.

7. Fall Clause

7.1 The BIDDER undertakes that it has not supplied/s not supplying similar product/ systems or subsystems at a price lower than that offered in the present bid in respect of any other Ministry/ Department of the Government of India or PSU and it is found at any stage that similar product/ systems or sub systems was supplied by the BIDDER to any other Ministry/ Department of the Government of India or a PSU at a lower price, then that very price, with due allowance for elapsed time, will be applicable to the present case and the difference in the cost would be refunded by the BIDDER to the EMPLOYER, if the contract has already been concluded.

8. Independent Monitors

8.1 The EMPLOYER has appointed Independent Monitor Shri Jagdeep Kumar Ghai [P&TA, FS (Retd)] (hereinafter referred to as Monitor) for this Pact in consultation with the Central Vigilance Commission.

8.2 The task of the Monitor shall be to review independently and objectively, whether and to what extent the parties comply with the obligations under this Pact.

8.3 The Monitor shall not be subject to instructions by the representatives of the parties and perform their functions neutrally and independently.

8.4 Both the parties accept that the Monitors have the right to access all the documents relating to the project/ procurement, including minutes of meetings.

8.5 As soon as the Monitor notices or has reason to believe, a violation of this Pact, he will so inform the Authority designated by the EMPLOYER.

8.6 The BIDDER(s) accepts that the Monitor has the right to access without restriction to all Project documentation of the EMPLOYER including that provided by the BIDDER. The BIDDER will also grant the Monitor, upon his request and demonstration of a valid interest, unrestricted and unconditional access to his project documentation. The same is applicable to Subcontractors. The Monitor shall be under contractual obligation to treat the information and documents of the BIDDER/ Subcontractor(s) with confidentiality.

8.7 The EMPLOYER will provide to the Monitor sufficient information about all meetings among the parties related to the Project provided such meetings could have an impact on the contractual relations between the parties. The parties will offer to the Monitor the option to participate in such meetings.

8.8 The Monitor will submit a written report to the designated Authority of EMPLOYER within 8 to 10 weeks from the date of reference or intimation to him by the EMPLOYER/ BIDDER and should the occasion arise submit proposals for correcting problematic situations.

9. Facilitation of Investigation

In case of any allegation of violation of any provisions of this Pact or payment of commission, the EMPLOYER or its agencies shall be entitled to examine all the documents including the Books of Accounts of the BIDDER and the BIDDER shall

provide necessary information and documents in English and shall extend all possible help for the purpose of such examination.

10. Law and Place of Jurisdiction

This Pact is subject to Indian Law. The place of performance and jurisdiction is the seat of the EMPLOYER.

11. Other Legal Actions

The actions stipulated in this Integrity Pact are without prejudice to any other legal action that may follow in accordance with the provisions of the extant law in force relating to any civil or criminal proceedings.

12. Validity

12.1 The validity of this Integrity Pact shall be from date of its signing and extend up to 5 years or the complete execution of the contract to the satisfaction of both the EMPLOYER and the BIDDER/ Seller, including warranty period, whichever is later in case BIDDER is unsuccessful, this Integrity Pact shall expire after six months from the date of the signing of the contract.

12.2 Should one or several provisions of this Pact turn out to be invalid, the remainder of this Pact shall remain valid. In this case, the parties will strive to come to an agreement to their original intentions.

13. The parties hereby sign this Integrity Pact at _____ on _____.

EMPLOYER

BIDDER

Name of the Officer

Chief Executive Officer

Designation

NABARD

Witness

Witness

1.

1.

2.

2.

Annexure III

ARTICLES OF AGREEMENT

(On a Rs 200/- Non- Judicial stamp paper)

ARTICLES OF AGREEMENT made on this day of (month) between the National Bank for Agriculture and Rural Development (NABARD) (hereinafter called “the Bank”) and having its Head Office at C-24, G-Block, Bandra Kurla Complex, Bandra (E), Mumbai – 400051 of the one part and M/s (hereinafter called “the bidder or the consultant”) and having its registered office at of the other part.

WHEREAS the Bank is desirous of getting executed “.....” and has caused the technical and financial bids of the RFP showing and describing the scope of work to be done under the direction of Bank.

AND WHEREAS the said terms and conditions have been signed by or on behalf of the parties hereto.

AND WHEREAS the Bidder has agreed to execute upon and subject to the conditions set forth in the *technical & Financial bids and Conditions of Contract, work order* (all of which are collectively hereinafter referred to as “the said Conditions”) the work shown upon the said scope of works, and included in the Price Bid at the respective rates therein set forth amounting the sum as therein arrived or such other sum as shall become payable there under (hereinafter referred to as “the said contract amount”).

NOW IT IS HEREBY AGREED AS FOLLOWS: -

1. In consideration hereinafter mentioned, the Bidder will upon and subject to the conditions annexed, carry out and complete the works shown in the RFP, described by or referred to in the scope of works and in the said conditions.
2. The Bank shall pay the Bidder the said contract amount or such sum as shall become payable at the times and in the manner specified in the said conditions.
3. The said Conditions and Appendix thereto and the documents attached hereto shall be read and construed as forming part of this Agreement and the parties hereto shall be respectively abide by, submit themselves to the said Conditions and the correspondence and perform the agreement on their part respectively in the said conditions and the documents contained herein.

4. This Agreement and documents mentioned herein shall form the basis of this RFP.
5. This RFP is an contract for carrying out the work of “.....” and to be paid according to actual measured quantities at the rates contained in the Schedule of Quantity of Consultancy Services and probable quantities or as provided in the said conditions.
6. The Bank reserves to itself the right of altering the nature of work by adding to or omitting any items of work or having portions of the same carried out by engaging any other consultant (bidder) / agency at its sole discretion without prejudice to this contract. The bidder shall not have any right to claim loss of profit / loss of opportunity to work from the Bank.
7. The bidder shall have to submit the “no other claims certificate” along with the final bill and once the final bill is settled by the Bank, the bidder will not have any right to claim for either any tender related or non-related work.
8. All disputes arising out of or in any way connected with this agreement shall be deemed to have arisen at Mumbai and only the sole Arbitrator as appointed by both the parties upon mutual consent in Mumbai shall have the jurisdiction to determine the same.
9. That all parts of this RFP have been read and fully understood by the bidder.

IN WITNESS WHEREOF the Bank has set its hands to these presents through its duly authorized officials and the bidder has caused its common seal to be affixed hereunto and the said two duplicates/ has caused these presents and the said two duplicates here of to be executed on its behalf, the day and year first herein above written. (If the consultant is a company)

Signature Clause

SIGNED AND DELIVERED by the National Bank for Agriculture and Rural Development by the hand of Shri _____
 (Name & Designation)
 In the presence of:
Witness #1
 Signature: _____
 Name: _____
 Address _____
Witness #2

SIGNED AND DELIVERED by the bidder
 Shri _____
 (Name & Designation)
 In the presence of:
Witness #1
 Signature: _____
 Name: _____
 Address: _____
witness #2

Signature: _____
Name: _____
Address _____

Signature: _____.
Name: _____
Address: _____

Annexure IV

Pro-forma of furnishing the payment details of the bidder.

Name of the Bidder		
Contact Details	Name	
	Email	
	Phone No	
PAN details (enclose copy of PAN)		
GST Number (enclose copy of GST registration)		
Address of principle place of business in the state as per GST registration certificate	Address	
	City	
	PIN	
	State	
Bank account number		
Account Name		
Type of the account		
Name & Address of Bank		
IFSC Code (enclose copy of cancelled cheque)		

Name of the Consultant:

Date:

Place:

Signature with seal:

Location for the proposed Experience Centre

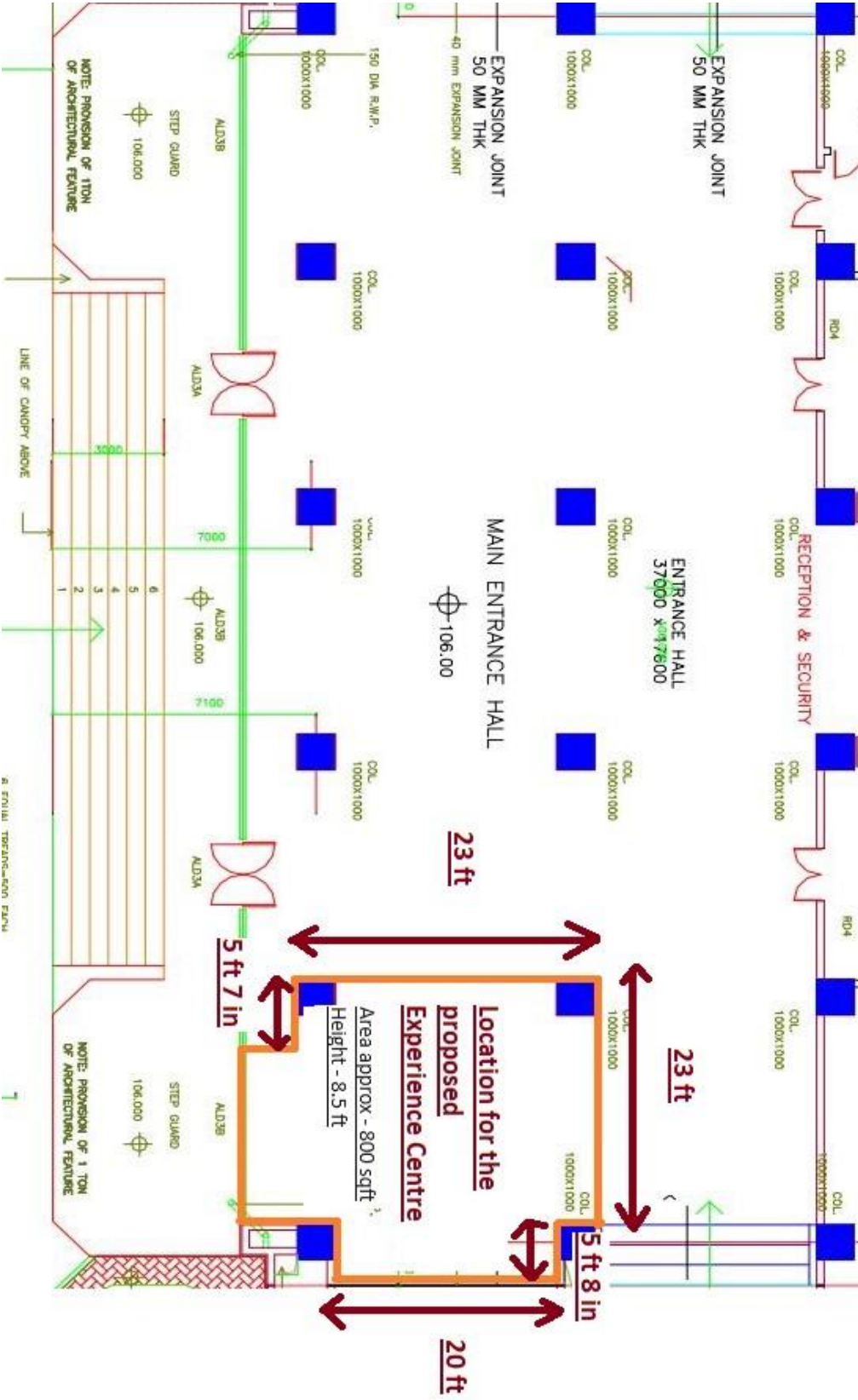

Financial Bid

(To be submitted online through CPPP Portal)

Name of the work: Request for Proposal from the empanelled consultants for the selection of consultant for the project of setting up of Experience Centre at NABARD Head Office Building, Mumbai.

Schedule of Quantity of Consultancy Services

S. No	Description of work	Quantity	Unit	Estimated cost of the project [₹]*	Quoted Rate. (as % on estimated project cost) [%]	Total Amount of consultancy charge quoted (₹)
1	2	3	4	5	6	(Col 5 * Col 6)/100
A	Providing Design cum Architectural Consultancy services and project management consultancy for setting up of Experience Centre at NABARD as per the scope of works in the RFP complete in all aspects. [fee quoted by the bidder shall be inclusive of all cost as well as profit, overheads/Income Tax as applicable. TDS will be applicable against the payment]	1	Job	1,20,00,000		
B	SGST @ 9 %					
	CGST @ 9%					
	Grand Total (A+B)					
C	Total Amount in words					

* Estimated Cost of the project is given for the purpose of arriving absolute figure in price bid.

Accepted all terms and conditions of this RFP.

Place:

Date:

Name, Address and Seal of the Bidder